

Review

Future Challenges and Mitigation Methods for High Photovoltaic Penetration: A Survey

Temitayo O. Olowu, Aditya Sundararajan , Masood Moghaddami and Arif I. Sarwat *

Department of Electrical and Computer Engineering, Florida International University, Miami, FL 33174, USA; tolow003@fiu.edu (T.O.O.); asund005@fiu.edu (A.S.); mmogh003@fiu.edu (M.M.)

* Correspondence: asarwat@fiu.edu; Tel.: +1-305-348-4941

Received: 18 June 2018; Accepted: 2 July 2018; Published: 6 July 2018



Abstract: Integration of high volume (high penetration) of photovoltaic (PV) generation with power grids consequently leads to some technical challenges that are mainly due to the intermittent nature of solar energy, the volume of data involved in the smart grid architecture, and the impact power electronic-based smart inverters. These challenges include reverse power flow, voltage fluctuations, power quality issues, dynamic stability, big data challenges and others. This paper investigates the existing challenges with the current level of PV penetration and looks into the challenges with high PV penetration in future scenarios such as smart cities, transactive energy, proliferation of plug-in hybrid electric vehicles (PHEVs), possible eclipse events, big data issues and environmental impacts. Within the context of these future scenarios, this paper reviewed the existing solutions and provides insights to new and future solutions that could be explored to ultimately address these issues and improve the smart grid's security, reliability and resiliency.

Keywords: smart grid; high PV penetration; challenges; mitigation; big data

1. Introduction

The growing concern for the depletion of the ozone layer and climate change [1,2], partly caused by power generation from conventional sources, have stirred many countries to make several projections for large-scale integration of renewable energy sources into their grids [3,4]. Consequently, the proliferation of power generation from photovoltaics (PV) systems compared to other forms of renewable energy sources has increased in recent years [5,6]. The fall in the prices of solar PV panels and the supporting policies made by various government of many countries have aided the growth in PV usage [7–9]. Figure 1a [10] shows the top 10 countries with solar PV installations in the world. China, with abundant rare earth metals [11], accounts for almost 34% of the total world's installed capacity with more than twice that of Japan (with the second largest PV installation capacity in the world). Figure 1b [10], shows the aggregate global PV installed capacity. The figure shows the consistent increase in the installation of PV globally. Over 375 GW of PVs were installed between 2007–2017. Figure 2a, shows the yearly PV capacity additions across the globe. This capacity additions have been on the increase consistently except between 2011–2012 and 2013–2014. Figure 2b [12], shows the percentage of global PV capacity additions in 2017, accounting for more than 60% capacity additions in 2017. The increase in capacity additions is expected to continue based on projections [13], with China projected to take the lead.

A report by [14] showed that over half of solar installations in US were connected to the distribution system. There is a projection that 50% to 60% of total US PV capacity from now till 2020 would be connected to the distribution system.

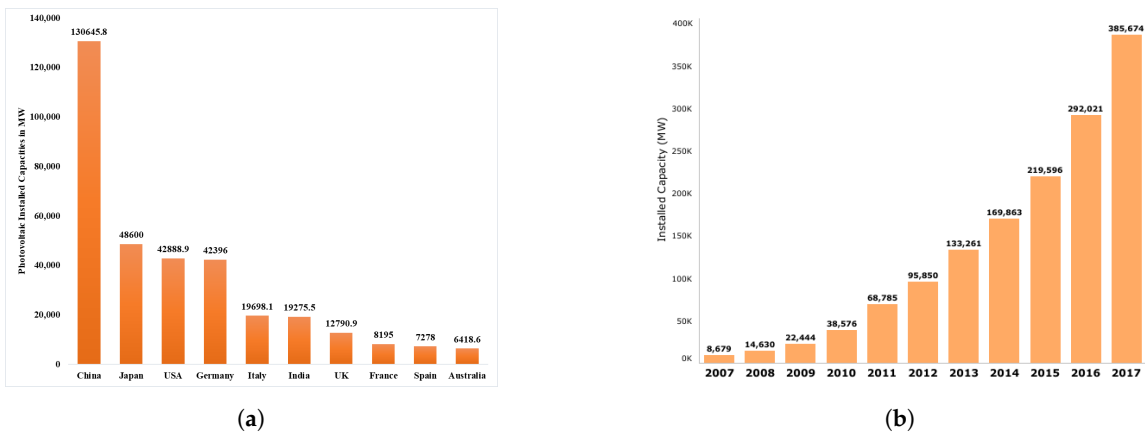

Figure 1. (a) Top 10 PV installed capacities in the world; (b) Total PV installation across the globe from 2007–2017 [10].

There was a 76% rise in residential PV installation capacity in the first quarter of 2015 [15]. In Germany as at 2013, of the total capacity of PV power installation, more than 70% of the installed PV total capacity is tied to the low-voltage (LV) distribution grid [16].

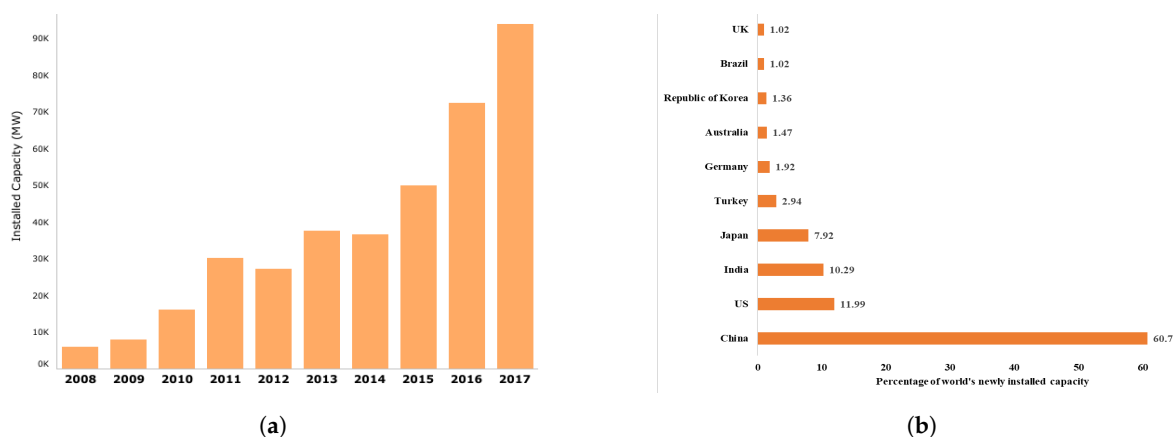

Figure 2. (a) Yearly global PV capacity additions [10]; (b) % of global PV capacity additions by countries in 2017 [12].

The need for decentralized (distributed) power generation has led many of these PV systems to be integrated with the low-voltage distribution grid. The increase in PV penetration into the grid, however, has its own challenges. The severity of these challenges most times becomes aggravated with the increasing level of PV penetration [17]. These challenges also depend on the point of interconnection of the PV systems on the grid [18,19], as well as the state and nature of legacy devices already installed on the grid. The proliferation of PV systems tied to the low voltage distribution grid makes it imperative to review the challenges (both present and future) on distribution grid network systems with high PV penetration and also propose some possible solutions to mitigate these challenges. The remainder of this paper is organized as follows. Section 2 presents a summary of the various high penetration PV challenges with their classification. Section 3 highlights these challenges within the context of future scenarios, while Section 4 highlights the existing solutions with some future directions. Section 5 presents a summary of Sections 3 and 4, and finally Section 6 concludes the survey.

2. High PV Penetration Challenges

Various definitions for the PV penetration level have been presented in different studies. According to [20], PV penetration was defined as the ratio of maximum PV power to the maximum

apparent power of the load. In [21], PV penetration is defined as the ratio of total PV energy generation to total energy generation. Cheng et al. [22] defined it as the ratio of total PV name-plate to the annual circuit peak load. Paper [23] defined PV penetration on the low voltage network as:

$$PV_{pen} = \frac{S_{PV\ feeder}}{n_{loads} S_{peak}} \quad (1)$$

where $S_{PV\ feeder}$ is the PV power installed under a given feeder, n_{loads} the number of consumers tied to the feeder, and S_{peak} an estimated value of peak PV power at the feeder. These definitions [20–23] are regarded as traditional definitions with several limitations according to [24]. The limitations in these definitions include the effects of PV in voltage regulation, the possible over-voltage due to earth fault and the possibility of islanding when there are light loads on the feeders.

Various works gave different percentage values as high PV penetration. Authors of [25] suggested values greater than 20% of total generation, while reports by [26,27] consider high penetrations to levels up to 15% and 50%, respectively. Although there is no literary standard as to what percentage of PV penetration constitutes a high PV penetration, as a rule of thumb, many works suggest that at penetration above 15%, the challenges of high PV penetrations becomes noticeable [28,29].

Challenges with Present Level of PV Penetration

Several countries have achieved some relatively high level of PV integration. Presently, Germany has about 20% with close to 50% of peak demand [30], California in the US have achieved 20–25% penetration [31], and Hawaii has already achieved a 19% with studies showing a possible 55% penetration [32]. Several studies have been carried out on the various challenges of the present level of PV penetration [16,20,33–63].

The intermittent nature of the PV output, its lack of inertia [64–66] like synchronous generators, and the unidirectional power flow nature of the distribution network present a huge challenge for higher levels PV penetration. The challenges highlighted from references [16,20,33–63] are within the context of present level PV penetration. Most of these challenges are still incipient. These challenges within the current level of PV integration are classified in to six segments based on their areas of impact as shown in Figure 3.

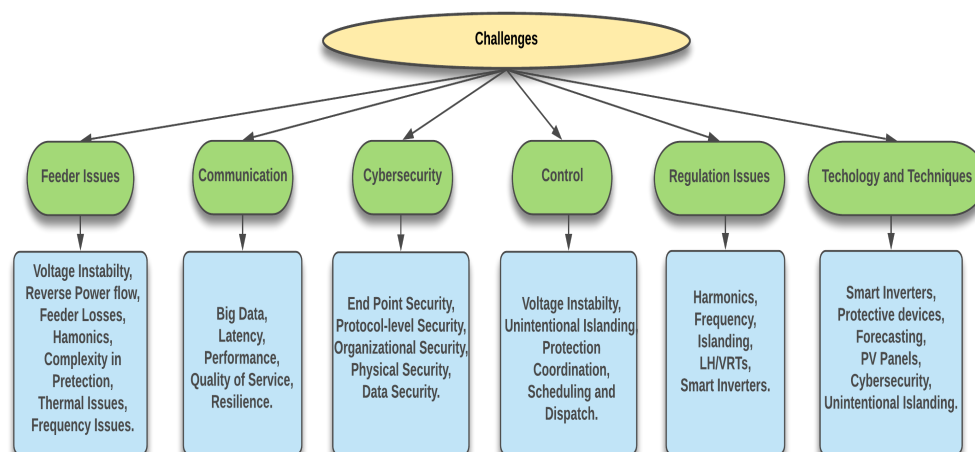

Figure 3. Classification of various challenges with PV integration.

3. Envisaged Future Challenges of Very High PV Penetration

Globally, there have been consistent increase in PV penetration by power utility companies. Figure 4 shows the present PV generation in 10 states in the US [67]. Nevada, California, Hawaii,

and Vermont are all projected to have solar penetration levels above 20% by 2021 [68] and the total generation of 135 GW in 2040 in the US [69].

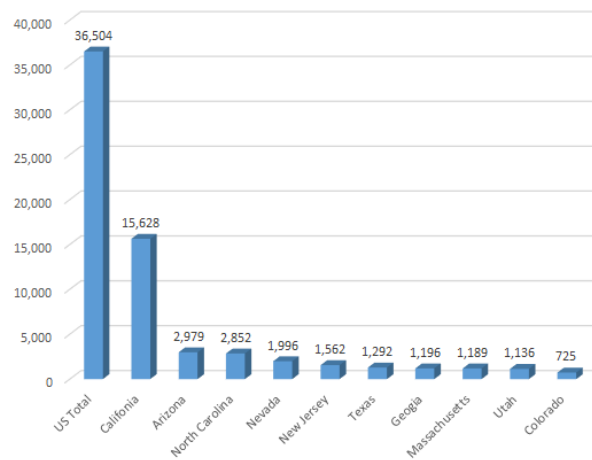

Figure 4. Top 10 net PV generation from utility and small scale year-to-date through June 2017 (Thousand Megawatthours).

This continuous increase in PV penetration will obviously pose more technical challenges in the future, definitely more than what we have at the moment. With high level of PV penetration, a sudden change in cloud movement or an expected solar eclipse could lead to some serious ramping in the PV output. This could be as high as 60% of the power output in within a fraction of a second [70], and 63% of PV output capacity within a minute [71]. This ramping would have greater effects which a very high level of PV penetration—say 50%. New control strategies have to be developed to cope with these impending challenges. Improvements have to be made in weather forecasting in other to call into action storage facilities and other forms of energy generations to mitigate the severe ramping of the PV output.

The increasing penetration of PV systems requires a proactive approach to the future scenarios. Figure 5 shows a typical future smart grid in the presence of more smart cities, smart home systems, plug-in hybrid electric vehicles (PHEVs), more utility-scale PV systems and increased prosumers.

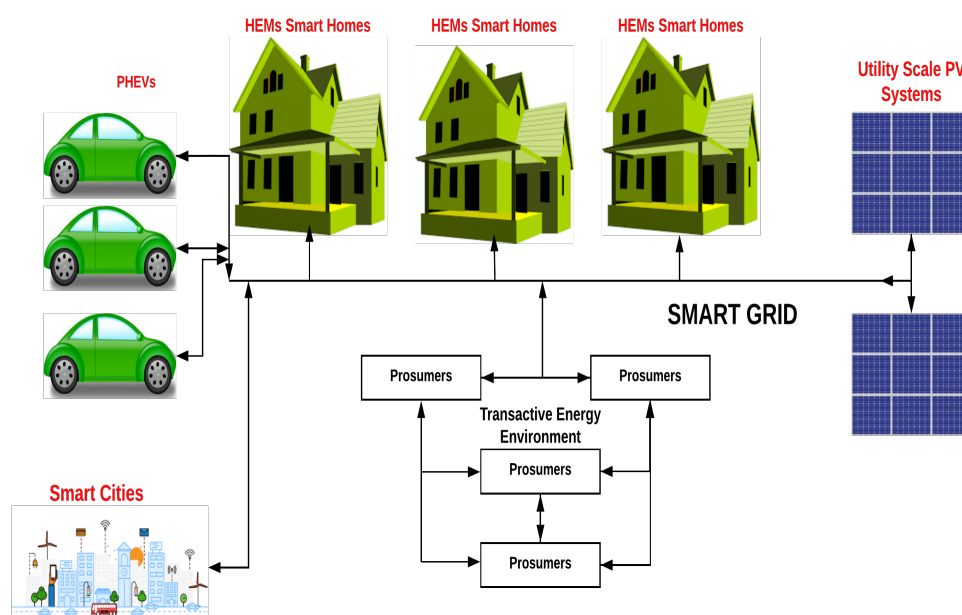

Figure 5. A future scenario with high PV penetration.

3.1. Future Impacts of PHEVs

Since its launch in the automotive market in 2010, the use of PHEVs has increased drastically. There is a projection that by 2020, there would be at least 2.5 million PHEVs in the automotive market [72]. There have been some designs of solar hybrid electric vehicles [73,74]. These vehicles are projected to drive the future of the automobile industry. Authors of [75,76] suggested that PHEVs are inevitably going to play a major role in the dynamics of the smart grid system in the future. A study carried out by [77,78] showed the effect of various levels of penetration of PHEVs into the smart grid at different seasons of the year. When PHEVs are being charged or discharged in large numbers, there would definitely be some significant challenges on the overall grid stability and power quality [79]. Belmin Memisevic et al. [80,81] showed that PHEVs do have impacts in peak load and power losses, as well as overloading the transformers with a high level of PHEV penetration and uncontrolled charging. Though high PV penetration could help mitigate this power loss, it would violate voltage limitations through a period of high solar insolation. With companies unveiling their various on-road dynamic wireless charging technologies that would inevitably be powered with solar panels, the level of impact of these systems on smart grid with high PV penetration is yet to be ascertained.

3.2. Smart Cities

Internet of Things (IoT) enabled smart cities would allow billions of devices and systems to be connected through the Internet [82]. The concept of smart economy, governance, people, mobility, buildings, services, infrastructure, surveillance, planning and environs means a whole new technical challenges for the smart grid with high PV penetration.

Achieving sustainable power supply for the realization of smart cities means the smart structures would have their own energy management systems [83]. Most of the buildings for smart cities are proposed to be Net-zero-energy buildings (NZEBs). These are buildings with extremely low energy demand. Such buildings are designed with very high energy efficiency. There is little difference in the energy demand by the building and energy supplied to the building can be made up by the installation of renewable energy (RE) systems on the building. A NZEB building can supply its excess power generation to the grid [84]. This is in tandem with the distributed energy systems for a smart grid. Many more rooftops, parking garage solar PV systems will be developed with the NZEBs.

There is also a projected increase in shared renewables such as community solar system [85]. These systems would form some micro grids that would also be integrated with the larger grid system for a bidirectional energy transfer. This would also usher in the new concept of the nanogrid which would enable individuals with power generation capabilities from renewable energy sources to become prosumers (both energy consumer and producer) [86]. There would be future clusters of several prosumers connected through the nanogrid to the main grid as shown in Figure 5.

With the certain dependence of smart cities on renewables, especially the use of PVs, the variability of PV power output is expected to pose some technical changes that have to be mitigated.

3.3. Future Impact of Solar Eclipse with High PV Penetration

Solar Eclipse occurs when the moon (which is opaque) passes between the sun and the earth. The prediction of this occurrence is usually accurate with the time and areas to be affected known.

The first of such event that had a huge impact on PV generation happened on 20th of March 2015 in Europe. A total of 21 GW of power was lost within 90 min [87], while Germany lost 9 GW of installed capacity within 75 min [88]. Many continental European countries also had some slight frequency stability issues during the eclipse [89]. Another solar eclipse occurrence is expected in Europe by 2021 and 2026. There is a projection that the total PV installation in Europe will rise to 170 GW and 250 GW by 2021 and 2026, respectively [90]. As a consequence, the occurrence of an eclipse in 2021 and 2026 eclipse would be more challenging.

The 21 August 2017 solar eclipse in North America also came with its own challenges. A report by [91,92] showed that PV power generation from utilities fell by 3.5 GW and rooftop solar installation power lost an estimate of 1.5 GW in California. North Carolina's generation was estimated to drop from 2.5 GW to 0.2 GW. Figure 6 [93] shows how the obscurity of the solar eclipse affected the PV power generation in 10 states in the US. The obscurity was estimated as a percentage of the scenario with total solar eclipse .

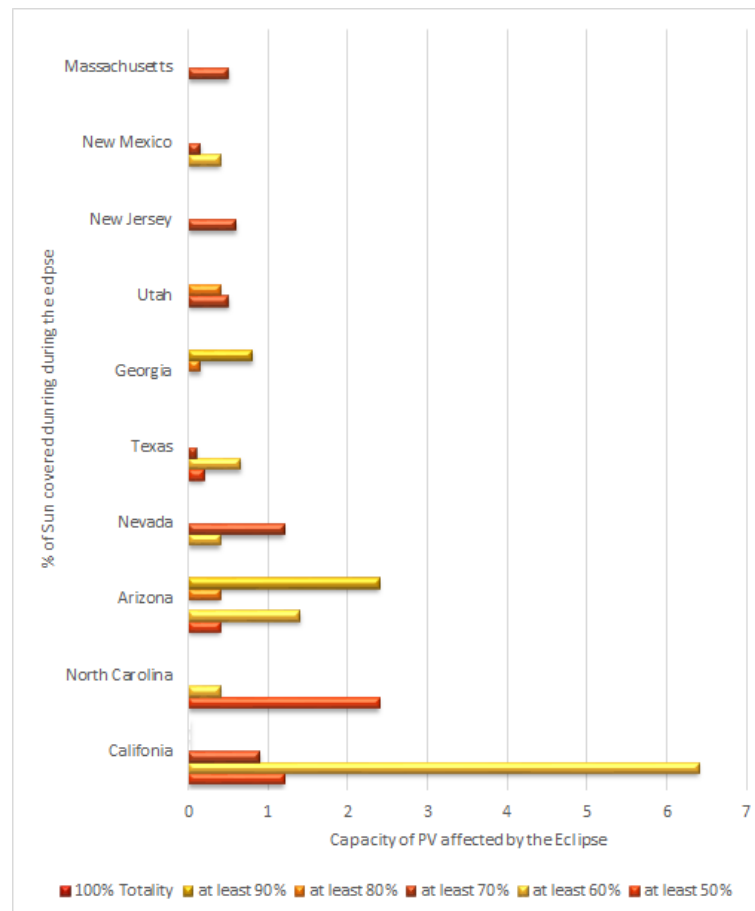

Figure 6. The effect of 21 August 2017 on PV generators in the US.

Figures 7 and 8 shows a 15 min resolution data plot of the actual AC power generation from two PV sites in Florida. One of the PVs (Figure 7), with an installed capacity of 1.4 MW, is located on Florida International University (FIU), Engineering Campus while the other with a name plate capacity of 356 kW (Figure 8) is located at Daytona in Florida. The FIU PV site showed a total drop in power generation of 660 kW within 60 min (1:45 p.m. to 2:45 p.m.). That is approximately a ramp rate of 11 kW/min. The other PV site in Daytona ramped from 251 kW at 1:00 p.m. to 25 kW at 2:45 p.m. This is equivalent to a ramp rate of 2.3 kW/min. The present level of penetration of the FIU PV is approximately 16%, based on the load on the feeder where the PV is connected. An impact study of this event was carried out. The system was able to cope with the loss in power generation. The power quality at the point of interconnection wasn't compromised. Obviously, with higher level of penetration, such occurrences will pose more challenges to the grid.

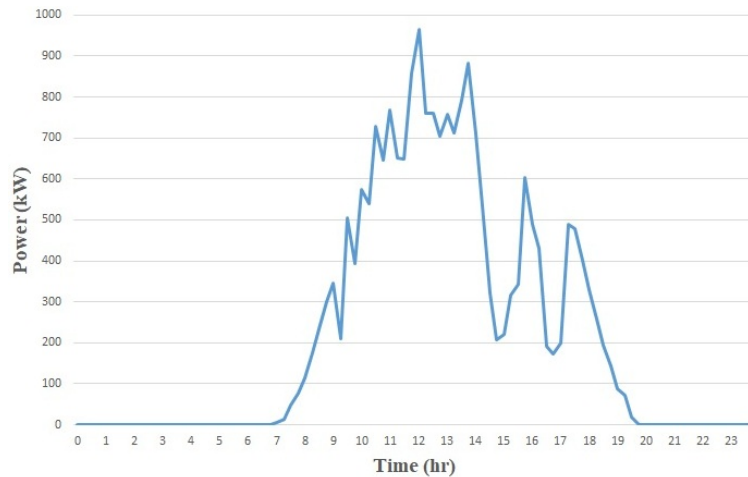

Figure 7. Power ramps at FIU PV site during the 21 August 2017 partial eclipse.

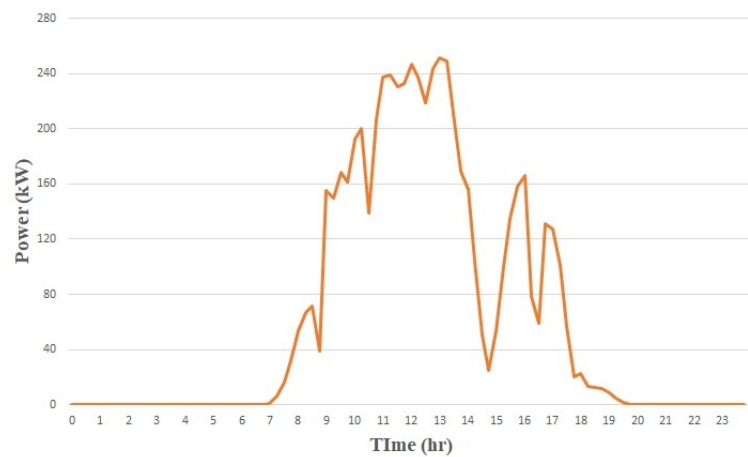

Figure 8. Power ramps at Daytona PV site during the 21 August 2017 partial eclipse.

The North American continent is also expected to witness another solar eclipse on the 8 April 2024 [94,95]. It is projected, with the present PV installation growth, that the total utility-scale PV generation in the US would rise to 50 GW by 2022 [69]. This implies that no less than 50 GW of PV capacities is expected to be connected to the grid when the next solar occurrence would occur in 2024. The ramping effects of 21 August 2017 solar eclipse events were mitigated with adequate forecast and preparations. Several other sources of power such as fossil fuel were used to offset the drop in power generation so as to maintain power system stability [92].

With the increased drive towards a higher level of PV penetration, it is quite obvious that the technical challenges of future occurrence of solar eclipses will be more prominent. This paper takes a look at the various challenges that could impede the stability of the smart grid with high level of PV integration and proposes several solutions that would help mitigate some of these issues.

3.4. Transactive Energy Concept

The GridWise transactive energy (TE) framework (Version 1.0) [96] defined the TE as a future electrical system (infrastructure) where the balance of supply and demand is achieved in a dynamic way. This is done within a framework of economic and control mechanism and each of the operators in the transactive environment gets value for their participation (inputs). The smart grid dictionary [97] also defined TE as a 'software-defined grid managed via market-based incentives to ensure grid reliability and resiliency. This is done with software applications that use economic signals and operational information to

coordinate and manage devices' production and/or consumption of electricity in the grid. Transactive energy describes the convergence of technologies, policies, and financial drivers in an active prosumer market where prosumers are buildings, EVs, microgrids, VPPs or other assets'.

Future TE scenario would involve total decentralization of the energy power flow. A multidirectional path for electricity would evolve. The TE architecture allows prosumers to transact energy within themselves at the distribution levels. TE would lead to the deployment of home energy management systems (HEMSs). A future TE scenario would involve total decentralization of the energy power flow. A multi-directional path for electricity would evolve. The TE architecture would allow prosumers to transact energy within themselves at the distribution level [98–100]. Most prosumers in the TE environment would have rooftop PV systems. The TE framework would encourage the proliferation of prosumers which would consequently increase the level of PV penetration. This future scenario with the nature of PV power generation is expected to pose a whole new challenge on the smart grid.

3.5. Big Data, Communication and Cybersecurity Issues

With increasing PV installations (both utility scale and rooftops), real time data acquisition and transmission becomes very crucial for efficient monitoring, management and control. The next decades will usher in the installation of hundreds of thousands of devices for different data-related purposes. This would consequently lead to some big data, communication and cyber-security challenges.

3.5.1. Big Data

With increasing penetration of distributed energy resources (DERs), such as PV in smart grid, there would obviously be an astronomical increase in the volume of data. These include, consumer energy utilization pattern data, smart meter data, data for managing, control and maintenance of devices (such as PMUs, IEDs, relays, etc.) data from generation, distribution and transmission networks, and operational data [101]. This volume of data as a result of increasing PV penetration conforms with the seven big data characteristics, which are [101–105]

1. Volume: There is an increase in the size of the data (smart inverter data, PV generation data, weather data, temperature data, data for forecasting, etc.) due to increasing PV penetration.
2. Velocity: The speed at which these data need to be acquired and transmitted increases. There is a need for real time control and data acquisition.
3. Variety: There is an influx of data from different sources. There is heterogeneity in the data sources including data from weather stations, PMUs, inverters, meters, power quality meters and other sensors. They usually have different format and structures which need to be processed.
4. Veracity: The accuracy of the data being transmitted and introduction of noise from the devices and other external sources.
5. Volatility: The length of time to store the acquired data.
6. Validity: This refers to the timeliness of the data, i.e., the value of the data is bound by time, after which it becomes irrelevant or invalid for processing.
7. Value: This refers to the end contribution of the smart grid big data in terms improving grid reliability, efficiency and resiliency.

3.5.2. Communication

The importance of an efficient and reliable communication architecture in a smart grid cannot be overemphasized [106]. There is certainly no realization of a smart grid without adequate and efficient communication infrastructure and network. With increasing PV penetration, the need for a highly efficient communication architecture becomes imperative. According to [107,108], the main requirements for communication infrastructure include an adequate Quality of Service (impacted by latency and bandwidth), interoperability, scalability, security and standardization. The massive data intrusion as a consequence of increased PV penetration could affect the Quality of Service (QoS).

Achieving low latency (time delay in data transmission) and adequate bandwidth while maintaining adequate efficiency and reliability becomes a very big challenge [109,110].

3.5.3. Cybersecurity

The influx of large data across the network, as a consequence of increased PV penetration, poses some cyber-physical challenges [111,112]. The deployment of communication infrastructures for data transmission and acquisition creates vulnerabilities for cyber attacks. Usually, the attackers try to take the advantage of the vulnerable parts of the communication architecture by attacking both the measurement and control signals [113–115]. For instance, a cyber attack on smart inverter communication and control signal on a feeder that has high level of PV penetration could lead to voltage and frequency instability. Smart inverter settings (such as Low/High Voltage Ride Through, Frequency Ride Through, Volt-VAR, and Frequency-Watt) remotely controlled through a Supervisory Control and Data Acquisition System (SCADA), could be changed by an attacker, which could lead to a cascade of stability problems in the grid [116,117].

3.6. Environmental Impacts with Increased PV Penetration

The much talked about environmental friendliness of power generation from PV doesn't come without some environmental impacts. These impacts could result as a consequence of the manufacturing process of the PV panels or as a consequence of the deployment PVs for use. According to the world energy council [118,119], the various environmental impacts of an increase in the use of PV can be classified under the following heading.

3.6.1. Land Use

Most of the land use for PV installations falls under utility-scale PV systems. The area occupied by a PV fleet is directly related to the size to be installed, the solar irradiance available at such location, the site's topography, the solar cell technology and efficiency. A study by NREL on how land was used for PV installations in US [120] showed that, 3.6 acres/GWh/yr was used for PV installations, while the area per unit average capacity was give as 8.9 acres/MWac. These values are based on data gathered up to the first quarter of year 2012. Generally speaking, utility-scale PV systems need an average of 12,000 m² to 40,000 m² per MW [119]. Unfortunately, unlike wind systems, land used for PV installations can hardly be used for agricultural purposes. The environmental impacts of vegetation clearing, digging, felling of trees and other massive construction works could have some wider environmental impacts on neighboring communities where these PV fleets are situated. The land use impact of mining of rare earth materials (tellurium, gallium and indium) used for manufacturing solar cells also poses some negative environmental impacts. China supplies almost 95% of the total rare earth metals used in the world [11]. The process of mining and recycling these metals in China could cause some climatic changes and could also be toxic to humans [121].

3.6.2. Water Usage

Although power generation from solar PVs does not directly require the use of water, the water usage is present in the manufacturing process and the cleaning of the modules during operation and maintenance. The typical water usage for manufacturing silicon based PV is 200 L/MWHR and an average of 15 L/MWHR is used during maintenance and operation [122]. The water use impact of increased use based on present studies has no significant direct impact on water quality. Only power generation from offshore wind has a lower value (4 L/MWH) of water consumption [11].

3.6.3. Hazardous Materials

PV modules contain heavy metals such as cadmium and lead [11], which could be hazardous when the solar panels are decommissioned. PVs made with thin-films cells contain harmful materials

such as gallium, indium and arsenic [118]. Also, during the manufacturing process of silicon-based PVs, silicon dust (kerf) are released, which could cause some breathing problems when inhaled. Also for cleaning and purifying the semiconductor surface of solar cells, hazardous chemicals such as Hydrochloric Acid, Hydrogen Fluoride, Nitric Acid, Acetone, 1,1,1-trichloroethane, and Sulfuric Acid are involved. These chemicals are typical of use in the semiconductor industry.

3.6.4. The Use of Natural Resources

Large quantities of minerals are required during the manufacturing process of PV panels due to the energy intensive nature of its manufacturing process [123]. These minerals include copper, iron and aluminum. According to [124], the quantity of iron used in manufacturing PV per unit kWh is higher than other forms of energy generation. This could lead to an enormous amount of mineral depletion.

3.6.5. Life-Cycle Emissions

The aggregate life cycle emission impact from PVs are assessed from its manufacturing process, its transportation, its installation and up to its decommissioning. The typical value of the life-cycle emissions from PV systems is between 30 and 80 g of Carbon (IV) Oxide [119]. The greatest emission cycle of the PV occurs during its manufacturing. The emission levels during its manufacturing process is dependent on the efficiency and the manufacturing technology used. Typical values of the energy required to manufacture 1 m² of poly-crystalline silicon PV is between 667 kWh and 2115 kWh and for the mono-crystalline variant is between 1470 kWh and 4580 kWh [119]. According to [118], the amount of emitted carbon (carbon footprint) as a result of solar panel manufacturing in China is twice that of solar panels manufactured in Europe. The emissions as a result of the transportation of solar panels, only accounts for 0.1–1% of the emission as a result of the manufacturing process [123]. Definitely, with the increase in PV installations, around the world, the impacts of these emissions would become significant.

3.6.6. Other Impacts

Other impacts of large scale deployment of PVs include: its impact on the biodiversity of the environment [118], its impact on visual and aesthetics of the environment [123,125], and its ecological impacts [118].

4. Existing Solutions with Future Directions

Several solutions have been proposed in literature to address these challenges. Obviously more work still needs to be done, especially in the future scenarios earlier mentioned. Table 1 shows a list of acronyms based on literature and some suggested solutions.

Amongst the solutions that have been proposed and deployed over the years with suggested future directions include:

4.1. The Use of MIR and RPFER

The minimum import relays are relays that are designed to disconnect grid-tied PV connected systems whenever their output falls below a particular threshold value. It's also used to trip the grid-tied PV system from the network whenever their output goes above the 25% of the actual service load.

Figure 9 shows a typical set up of how the MIR can be integrated with a grid-tied PV system [24]. The MIR communicates with the grid-tied inverter system to disconnect whenever the output falls below a threshold value.

While the RPFER is designed to disconnect the grid-tied PV system when the power flow from the utility falls to zero or changes to the opposite direction. This relay trips to prevent back feed upstream of the feeder or to neighboring feeders [24,62,126–133].

Table 1. Acronyms for Solutions.

MIR	Minimum Import Relay
RPF	Reverse Power Flow Relay
SI	Smart Inverter
SI_{LC}	Smart Inverter with Load Control
SI+DLHC	Smart Inverter with Dynamic Load Harmonic Control
D-SCADA	Distribution Supervisory Control and Data Acquisition
AMI	Advanced Metering Infrastructure
ADMS	Advanced Distribution Management System
ST	Smart Transformer
ARCPC	Advanced Relay Communication and Protection Coordination
FRT	Fault Ride Through
OER	Optimal Energy Routing
IED	Intelligent Electronic Device
DCESS	Dynamic and Composite Energy Storage Systems
GS	Geographic Smoothing
VVWO	Volt-VAR/Watt Optimization
DERMS	Distributed Energy Resource Management System
GIS	Geographic Information System
CIS	Customer Information System
STLF	Short Term Load Forecasting
SE	State Estimation
MDMS	Meter Data Management System
FLISR	Fault Location, Isolation and Service Restoration
OMS	Outage Management Systems
CRM	Customer Relationship Management

Figure 10 is a typical block diagram of the RPF according to [130]. The relay constantly monitors the direction of power flow by taking current and voltage input from the CT and PT. A reversal in the direction of flow of power causes the relay to send a trip signal to the RPF breaker to disconnect the grid-tied PV system.

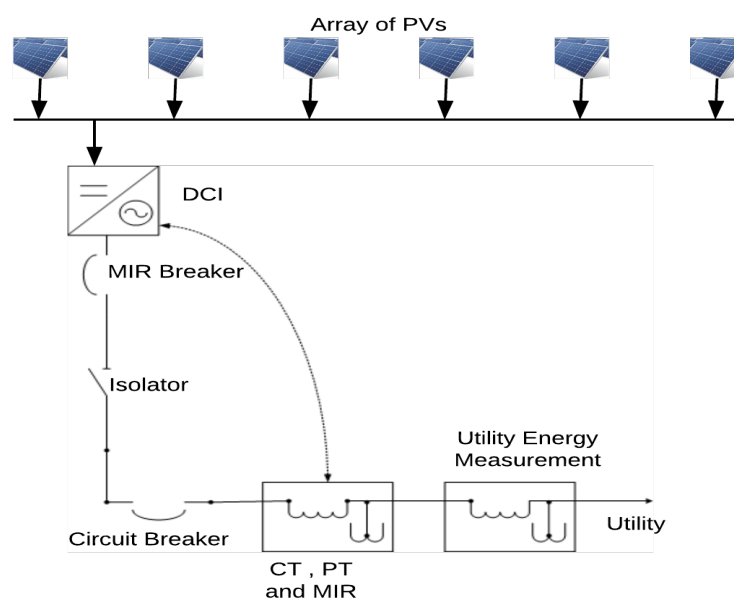
**Figure 9.** Integration of an MIR with a grid-connected PV.

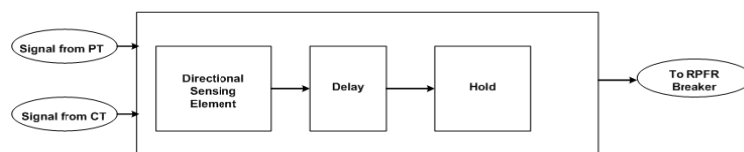

Figure 10. Basic block diagram of an RPFR.

The MIR and RPFR have a vital role to play in mitigating the effects of reverse power flow and possible voltage instability issues.

4.2. DCI and Smart Inverter Functionalities

The DCI are inverters that can dynamically control its output power by ramping up or down based on the loading condition on the feeder the grid-tied inverter is connected to [24,127]. The loading on the feeder is constantly monitored and a control signal can be sent to the inverter to cut down or ramp up its power output based on the load profile on the feeder. This type of inverters can help mitigate against reverse power complementing the use of MIR and RPFR.

Also, smart inverters will have a vital role to play in the future smart smart grid. The IEEE 1547a as amended in 2014, allowed the use of smart inverters for voltage regulation on the feeders. The recent IEEE 1547-2018 [134] describes the various standards for inverter-based DER integration with the grid [135]. Table 2 shows some of the essential functionalities for smart inverters according to [135]. With high PV penetrations, these functionalities of smart inverters can help mitigate many of the challenges associated with increasing PV (both utility scale and rooftops) penetration in the smart grid.

Table 2. Smart Inverter Functionalities.

Functionalities	Sub-Functionalities	Specific Settings
Voltage Ride Through (VRT)	Low/High VRT	Voltage, Duration (time)
Frequency Ride-Through (FRT)	Low/High FRT	Frequency, Duration (time)
Dynamic Volt-VAR/Watt Control	Volt-VAR, Volt-Watt	Volt-VAR/Watt Curves
Ramping		Ramp rates
Power Factor setting/control		Values
Soft start	Ramp rate, Time delay	
Limit Real and Reactive Power	Enable/Disable	
Frequency-Watt		Frequency-Watt Curve
Dynamic Current Support		
Output Scheduling		Time of start, Time to end, Real and Reactive power value, operational schedule
Frequency Deviation Support		
Control of Reactive Power Dynamically.		
Dynamic Load Control		
Dynamic Harmonic Control		

New smart inverter functionalities such as dynamic load control, dynamic harmonic control, frequency deviation support, output scheduling and future functionalities would be required to help support the smart grid [136–139]. More responsibilities for the grid would lie on the smart inverters. More functionalities would also be required for future smart inverters. The major concern for power

utility companies is usually the smart inverter setting that should be used for the several rooftop grid-tied PV systems. Most inverters at this scale are usually set at a power factor of unity to allow for maximum active power injection for maximum revenue to the small scale prosumers. New regulations for rooftop PV smart inverter settings will be needed as the number of grid tied rooftop PV continues to rise. With a well developed framework for smart inverters functionalities with high PV penetration, the use of legacy devices such as capacitor banks, On/Off load tap changers (OLTCs) and voltage regulators might become unnecessary for voltage optimization and control.

4.3. Dynamic and Composite Energy Storage Systems

Several articles have been published on how the use of energy storage systems can help to mitigate the impacts of the variability in the output renewable energy sources such as the PV systems. Dynamic energy storage is an energy storage that has some prediction, forecast, dynamic scheduling and control capabilities [140]. This type of storage system will enable an efficient power curtailment, reliable power smoothing and drastic reduction in the uncertainties associated with renewable energy generation. Composite or hybrid energy storage systems that uses both battery and capacitors (such as ultra and supercapacitors) have been proven to help mitigate both the fast ramps and slow ramps for grid-tied PV systems. The fast response time of capacitors when properly controlled could be used to mitigate the effects of fast ramp rates caused by fast moving clouds with PV generation [141,142].

Figure 11 shows how a typical DCESS architecture can be integrated with the smart grid.

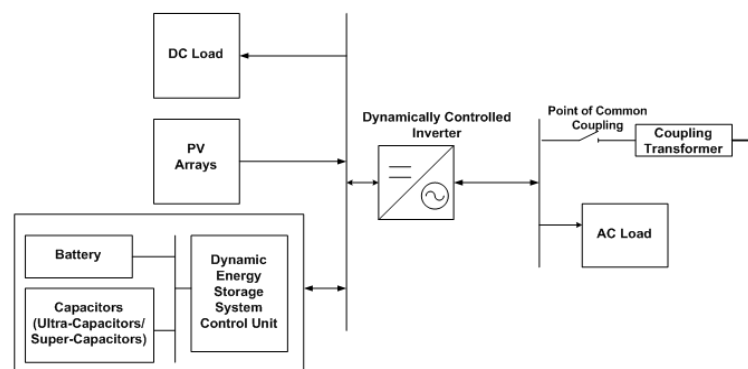

Figure 11. Block diagram of the integration of DCESS.

4.4. Solid State Transformers

The use of solid-state transformers would be highly beneficial to the future smart grid. This is due to its capability of interfacing as an AC and/or DC grid system and ease of dynamic control [143]. Consequently, these capabilities would allow ease of integration of distributed energy resources (DERs), such as EVs, high penetration PVs, energy storage, etc. The SSTs have the capability to improve power quality, protection and communication [144,145]. Figure 12 shows a conceptual design of a typical solid state transformer with a three-phase high voltage AC input and one-phase AC voltage output [146]. A typical SST has an AC-DC converter at its input, a DC-DC converter with a high frequency transformer (typical 10–20 kHz) and DC-AC converter at its output.

According to Wensong Yu et al. [147], SST could provide the benefits to the future smart grid within the following context.

1. Management of fault scenarios
 - Limiting of currents especially during fault scenarios
 - The ease of connecting and disconnecting of circuits attached to it
2. Power Management

- Ease and possibility of controlling the power flow in the system and the distribution feeder's power factor
 - The ease and flexibility of changing and controlling the customer's and/or the feeder's voltage.
 - It can provide DC power when needed
 - SSTs can be used to mitigate system harmonic which is one of the drawbacks of inverter-based DERs
 - The capacity of ride through during abnormal situations
 - It can provide support for the DERs when on the islanding mode
3. Energy Management Support
- Capability to for real time energy storage monitoring
 - Capability for power control and dispatch
 - SST can be integrated into the mix of demand side management

The present challenges with SST applications include lower efficiency compared to the electromagnetic induction based transformers, complexities is in protection, balancing of voltage and currents, communication and control, and insulation for high voltage levels [148]. Active research is ongoing to address these issues especially in application into the smart grid architecture.

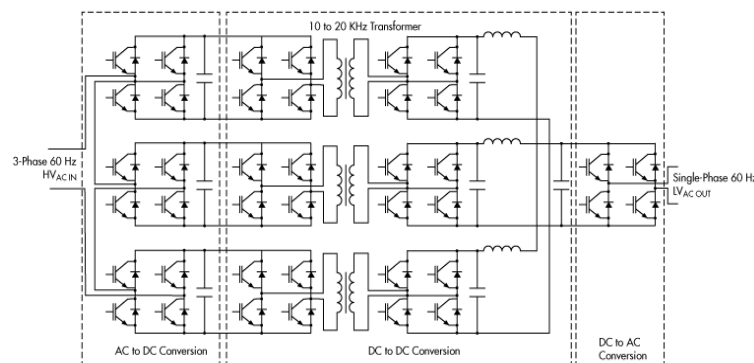

Figure 12. A conceptual design of a solid state transformer [146].

4.5. Optimal Energy Routing

With the integration of several prosumers and DERs (also in a microgrids) in the mix of power generation, the routing of these generated power to meet the load demand in the most efficient way becomes a big challenge [149]. Several optimal energy routing algorithms and power electronic topologies have been proposed and developed over the years. On the optimal routing algorithm development, amongst other authors, Hong et al. proposed the use of game theory based energy routing algorithms [150], while Kado et al. formulated the use of cost-scaling-push-relabel approach [151]. Additionally, several topologies of power routers have been developed over the years. Kado et al. developed a multi-port routers for AC or DC power transfer [152], Hayashi et al. developed a digital grid router with bi-directional energy flow capabilities [153], an energy router that has the capability of intelligently managing energy flow between microgrids [154] was developed by Liu et al. and the use of smart AC/AC conversion systems [155] was developed by Kordonis et al. The basic functional requirement of a very good energy routing architecture is an efficient power electronic converter design, low latency in information exchange, highly reliable communication medium, high level of information and data security, and intelligent grid connectivity [156–160]. The development of an optimal and efficient energy routing algorithm would ensure an efficient energy transfer from the generating units to the load points. These would minimize the feeder losses and also improve the stability of the grid with a high penetration of PVs.

4.6. Distribution Supervisory Control and Data Acquisition (D-SCADA) with Advanced Distribution Management System (ADMS).

The ADMS is a software architecture that allows automated management of the grid infrastructure by optimizing the distribution system, providing an outage restoration procedure that is automated. It also has an important feature called Fault Location, Isolation and Service Restoration (FLISR), which automatically locates a fault, isolate the faulty section (using automated switches) and restore services to the non-faulted part of the network. With high PV penetration, installation of more rooftop PVs, electric vehicles, integration of micro and nano grids, and other distributed energy resources (DERs), the ADMS will allow for smooth integration and efficient management of these sources. It will also be used as the base for implementing conservative voltage reduction and VVWO in the grid. Figure 13 shows an ADMS architecture with its features according to reference [161,162]. This architecture features integration of several enterprising softwares through the enterprise bus. The ADMS features, such as short term load forecasting (SLTF), distribution planning, and distribution energy resources management systems (DERMS), would allow for ease of dynamically control of the grid and improvement of the grid reliability and resiliency. The integration of this architecture at the utility substations will definitely mitigate many of the challenges associated with increasing PV penetration and other DERs [163–166]. From a utility company’s experiences [163], the major challenges with smooth integration of this architecture with the existing grid systems include interoperability of these enterprising softwares from the different vendors providing them, modeling of the existing infrastructure on the softwares, validation of the solutions provided by these architectures as an optimal one and many other unique challenges.

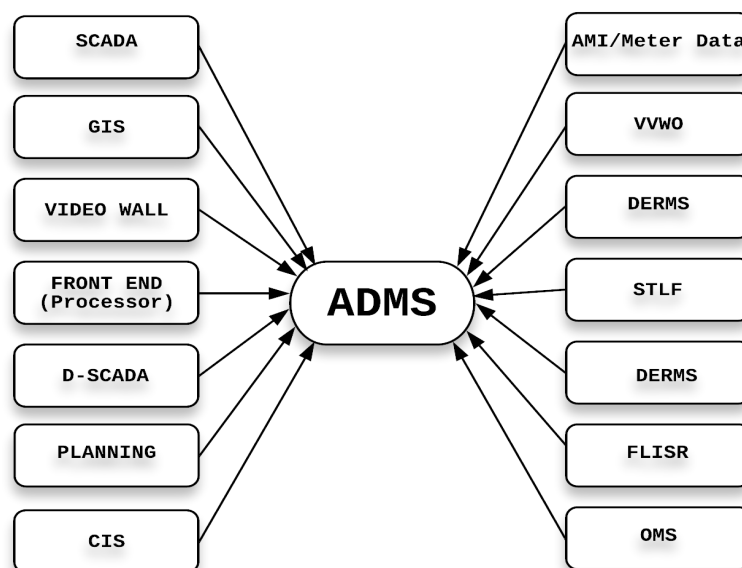

Figure 13. ADMS architecture and its typical features.

4.7. Advanced Relay Communication and Protection Coordination (ARCPC)

The reliability and the resilience of a smart grid architecture is dependent on the effectiveness of its protection systems. Many authors have proposed several adaptive and intelligent protection systems that use IEDs [167–173]. The IEDs, such as digital protective relays (DPR), have the capability to sense voltage, current and frequency, issue control commands, and process and communicate data. The adaptive protection scheme should be capable of some self-awareness, self-reconfiguration and self-healing. More recently, the idea of using a multi-agent system based protection system for the smart grid was proposed [174–177]. An agent is usually referred to as any hardware or software that is capable of intelligent and autonomous operation based on its intended design objectives [178,179].

This multi-agent architecture can be easily deployed for optimal protection coordination. The protection architecture agents can be broken into the relay agent, the DER agent and the equipment agent. These agents would be linked together with a communication infrastructure [174–177,180,181]. Overall, more adaptive and intelligent techniques of protection coordination need to be developed to cope with the future dynamic nature of the smart grid with increased PV penetration.

4.8. Geographic Smoothing and Optimal Location of PV Systems

Fleet management with optimal sizing and siting of PV systems would help mitigate against some challenges as a consequence of the intermittent nature of PV [182–188]. Several factors such as feeder losses, voltage profile, cost, line ampacity and the existence of previous PV installations are some of the primary factors to be considered when siting and sizing a PV on an existing feeder. Depending on the correlation in the Global Horizontal Irradiance (GHI) of different locations, aggregating PV systems could potentially reduce the variability (and ramp rates) in the output of the aggregated PV systems. For sites that have very small correlation values, the aggregation of PV in these areas could lead to a large reduction in variability of the aggregated PV compared to each of the PV site. Aggregating PV sites with very strong correlation in GHI will produce less reduction in variability in the aggregated PV site. This is often referred to as geographical smoothing of PV power output. This is mostly applicable to utility scale PV systems. Several case studies have presented the effects and benefits of PV aggregation [189–194].

The optimal location of PV systems along a feeder with the objective of minimizing losses, reducing the possibility of reverse power flow, and preventing over-voltage could be of immense benefit with higher levels of PV penetration.

4.9. Optimal Mix and Dispatch of Renewable Energy Sources

Being the two fastest growing sources of power generation from renewable energy sources, several studies have shown the benefits (the complimentary nature of solar irradiance and wind speed [195–198]) of hybrid generation from a mix of renewable energy sources such as wind and PV systems [199].

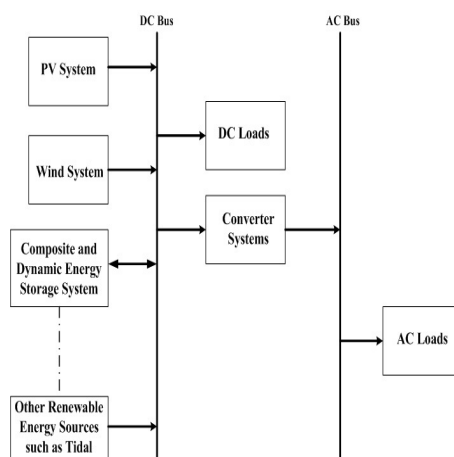

Figure 14. Basic block diagram of a hybrid DER generation.

Other distributed energy resources (DERs), such as battery energy storage [200] and most recently tidal [201], have been proposed as part of a composite hybrid system to address the challenges of power generation from PV systems alone. Several techniques and algorithms have been proposed to determine the optimal mix and capacity dispatch using a hybrid of these renewable energy resources. For optimal sizing of a hybrid of Wind+PV+battery, Akram et al. and Singh et al. proposed the use of iterative search algorithms [200] and particle swarm optimization, respectively. Authors of [201] also

proposed the use of the crow search algorithm (CSA) for optimal sizing of PV+Wind+Tidal+Battery with its economic analysis. Figure 14 shows a block diagram with the integration of wind systems and other DERs with the PV system. Each of these DERs would have its own control mechanisms for optimal dispatch of its generation.

From the dispatch, scheduling and economic point of view, necessary algorithms can be developed to determine what amount (forecasting) of these sources would be available at a given point in time as well as the price signals (economics) to be used to determine the optimal dispatch of these hybrid sources [202,203].

4.10. Demand Response Management

To ensure grid (nano-grids, micro or the macro smart grid) stability, which could be threatened with high PV penetration, power generation must be able to meet the load demand plus the losses associated with transferring the power from the point of generation to the load. Conventionally, the generated power is usually controlled to meet the load demand at all times. The use of demand response management (DRM) techniques allow for a dynamic control (such as load shedding/curtailing, load shifting) of the load to match the energy generation in real time. The benefits of DRM include a reduction in power generation and costs to meet the load demand, reduction in variation of prices [204], increased reliability of the system [205], improved management of system congestion [206] and improvement of the overall system security [207]. The use of DRM algorithms provide an excellent way of overcoming the variable nature of power generation from PV systems by dynamically controlling the load to match the power generation. Some of the proposed algorithms for DRM include:

- The use of large time constant loads to create a virtual energy storage which is used to smoothen the intermittent output of PVs through DRMs [208].
- An IoT-based, real time smart-direct load control (S-DLC) was proposed by [209]. The algorithm creates a schedule for the customer loads, then controls and optimize the loads (which already has an intelligent electronic devices (IED) embedded) through a load shedding and forecasting algorithm.
- Karapetyan et al. proposed an event-based DRM using the greedy approach for customer load curtailment. An integer programming problem was formulated which estimated the amount of loads to be curtailed while using the maximum available generated power [210].
- Sivaneasan et al. [211] proposed a DRM algorithm that controls the air-conditioning and ventilation systems in a building. Whenever there is a drop in PV power generation, the developed systems adjust the air conditioning system by putting into consideration the well-being of the occupants of the building. This system incorporates a battery storage management system and a load shedding algorithms that is based on the level of priority of the loads.

The use of state-of-the-art DRM algorithms would be a vital tool in addressing the intermittent nature of power generation from photovoltaic systems.

4.11. Big Data Solutions

The characteristics (volume, heterogeneity, speed and veracity) of the data involved in operating a smart grid with high PV penetration constitutes a big data challenge [212]. Solutions to big data challenges needs a data storages with high capacity and very high processing speed. Some of the available solutions that can be leveraged on to solve the big data challenges are highlighted below.

4.11.1. Data Processing Frameworks

As mentioned earlier, the data volume necessitates the use of some big data processing framework. Examples of existing data processing frameworks that can be used include: Flink, Spark, Storm, and Hadoop [213].

4.11.2. Cloud Computing Frameworks

The use of cloud computing in big data allows utility companies to achieve some level of flexibility and efficiency in managing their data. Some available cloud service models that can be leveraged in a smart grid with high level of PV penetration include [214–217]:

- Software as a Service (SaaS)
- Infrastructure as a Service (IaaS)
- Platform as a Service (PaaS)
- Data as a Service (DaaS)
- Communication as a service (CaaS)
- Monitoring as a Service (MaaS)

4.11.3. Post-Cloud Computing Networks

To address the central architecture-based cloud computing frameworks (which is usually plagued by congestion, latency and reduced Quality of Service (QoS)), several other post-cloud computing paradigms have been proposed [218]. These include, Fog Computing [218,219], Mobile Edge Computing (MEC), and Dew Computing [219,220]. These new post-cloud computing paradigms ensure improved security, reduction in bandwidth, better scalability, improved visibility and decreased latency [218,221]. These computing paradigms can be leveraged on to address the computing challenges that will arise with increased penetration of PVs in the smart grid.

Other solutions that have been proposed to solve the challenges that emanates from big data include the use of game theory [222–224], and machine learning algorithms, such as deep learning [225–228], selective encryption [229–231], and defense-in-depth (DiD) [232,233].

4.12. The Use of Artificial Intelligence

The deployment of artificial intelligence (AI) could help to better integrate new PV and the existing ones with the grid. AI has the ability to use machine learning algorithms to analyze new and historical data, carry out some predictions and forecasting, execute some control operations and make some intelligent decisions. The use of AI can be deployed in weather forecasting (which includes irradiance, temperature, wind speed and cloud speed), determining the optimal size of PV systems, smart inverter controls, tracking of PV's maximum power point, system optimization and control, accurate estimation and identification of solar cell parameters and models, and diagnosing faults in PV systems [234–236]. AI uses machine learning algorithms, which is usually classified into Supervised and Unsupervised learning.

Examples of supervised learning techniques includes [237]

- Random Forest
- Deep Learning
- Generalized Linear Models (GLM)
- Decision Trees
- Gradient Boosting Machine (GBM)

Unsupervised learning techniques include:

- Principal Components Analysis (or Dimension Reduction)
- Anomaly Detection
- Clustering

According to [234], AI algorithms that have been applied to PV systems include: Neural Networks (NN), Fuzzy logic (FL), Simulated Annealing (SA), Genetic Algorithm (GA), Ant colony (ACO), Particle Swarm Optimization (PSO), Adaptive-Neuron Fuzzy Inference Systems (ANFIS), GA-fuzzy, and NN-fuzzy.

5. Summary of Present and Future Challenges with Suggested Combinatorial Solutions and Future Direction

With the present PV penetration level, many challenges with PV penetration are incipient as mentioned earlier. With the drive toward achieving a higher levels of PV penetration, many of these challenges with the future scenarios earlier mentioned would become more aggravated. Table 3 highlights these problems and the combination of solutions that could address these challenges based on the solutions highlighted in Section 4.

Table 3. PV penetration problems and suggested future solutions.

Challenges	Existing (with Present Penetration Levels)	Future (with Smart Cities, PHEVs, Solar Eclipse, Transactive Energy, Big Data, Cybersecurity etc.)	Suggested Future Solutions
Reverse Power flow	incipient problem depending on the point of interconnection with the feeder.	Increase expected. Reduced the choice of point of interconnection.	Minimum load ensured on feeders. MIR, RPPR. SI_{LIC} . SI+D-SCADA, AMI
Voltage instability issues	OLTC and DVRs has been effective.	Increase expected.	STs. DCESS, OLTC. STATCOMs. DVRs, SI+D-SCADA with FRT. GS with PV fleet management.
Complexity in protection coordination	No major issues with Coordination in relays, sectionalizers, fuses, reclosers.	Increased bidirectional flow of current and fault current levels, line to ground voltage increase due to more single phase prosumers, possible desensitization the substation relays, unwanted blowing of fuses, maloperation of reclosers and sectionalizers.	Advance short circuit analysis with high PV penetration. SI with fault current monitoring and control capabilities. ARCP
Power factor problems	No major concerns.	Increase expected.	Use of SI with dynamic reactive power control for both utilities and prosumers. SI+D-SCADA, OER.
Harmonics	No major concerns.	Increase expected.	All SI compliance with UL 1741. SI+DLHC capabilities. Use of STATCOMs
Frequency Instability	No major concerns. Germany's '50.2 Hz' problem .	Increase expected.	GS with PV aggregation for utility-scale PV systems. DESS. SI+FRT, OER
Feeder losses	Slight increase depending on POI	Possible future increase.	Robust optimal PV placement algorithms, OER on the distribution feeders.
Thermal limits of the grid	No significant effects	Increase expected.	UL 1741 compliance for all SI. Optimal placement of utility-scale and small scale aggregated PV system, OER
Security of supply	No major issue.	Threatened.	Accurate estimation methods of prediction (of security of supply) should include future market analysis consideration of the intermittent nature of PV system as well as the development of other dispatchable energy sources.

Table 3. Cont.

Challenges	Existing (with Present Penetration Levels)	Future (with Smart Cities, PHEVs, Solar Eclipse, Transactive Energy, Big Data, Cybersecurity etc.)	Suggested Future Solutions
Communication within Distributed Energy Resources (DER) and substation, Cybersecurity	No communication and control link. IEEE 2030 standard has not been fully developed.	Reliable and well defined communication and control protocols needed. Interoperability of DERs in a TE environment.	IEDs .Robust IEEE 2030 standards and adoption by all PV systems. Fast computing and communication architecture.
Dynamic modeling of the high penetration PV	GIS-based Distribution Management Systems (DMS) models PV systems as a negative load.	System modeling with PHEVs, and proliferation of prosumers would be required. Energy routing modeling for IoT enabled TE would be required. More detailed studies solar eclipse impacts would be needed.	Dynamic models PV systems should be developed for GIS-based DMS and GIS-based Energy Management Systems (EMS) for remote monitoring and control.
Forecasting	Forecasting always have some level of uncertainty. The level of accuracy is still low	Accuracy will be key to adequate planning, unit commitment and dispatch.	Hybrid-forecasting (nowcasting+forecasting). More accurate prediction models using multiple forecasting methods.
Dispatch and Scheduling problem	No major issues reported	Increase on PV penetration in transactive environment will require the implementation of optimal power flow and optimal dispatch with high PV penetration mandatory	Optimal Smart Inverter Dispatch (OSID). Optimal set point for storage systems. Mitigation techniques for forecast and communication errors in (OSID)

There is an obvious need for a proactive approach towards developing more advanced and smart protection systems and integrated technology that allows ease of DER penetration and control for improved reliability and resilience of the grid.

6. Conclusions

This paper presented the various challenges with PV penetrated network and classified them based on their areas of impact. With the inevitable future increase in PV penetration, this paper also took an extensive look at different future scenarios and their impacts with higher levels PV penetration in the network. The present technical solutions with the existing penetration was also presented. Many of these existing solutions need further development with some future research direction indicated in this survey. This survey showed that the technical, operational and environmental challenges with PV integrated network are still incipient and would become more prominent with increased level of penetration, especially within the context of the future scenarios earlier discussed.

Author Contributions: A.S., T.O.O., and A.S. conceived the ideas in this paper, T.O.O. reviewed the literatures and wrote the survey, A.I.S., Masood Moghaddami and A.I.S. reviewed the survey.

Funding: This material is based on a work supported by the National Science Foundation (NSF) under grant number 1553494

Conflicts of Interest: The authors declare no conflict of interest.

References

1. Chang, Y.P. Optimal the tilt angles for photovoltaic modules in Taiwan. *Int. J. Electr. Power Energy Syst.* **2010**, *32*, 956–964. [[CrossRef](#)]

2. Oshiro, M.; Tanaka, K.; Senjyu, T.; Toma, S.; Yona, A.; Saber, A.Y.; Funabashi, T.; Kim, C.H. Optimal voltage control in distribution systems using PV generators. *Int. J. Electr. Power Energy Syst.* **2011**, *33*, 485–492. [[CrossRef](#)]
3. Setiadi, H.; Krismanto, A.U.; Mithulananthan, N.; Hossain, M.J. Modal interaction of power systems with high penetration of renewable energy and BES systems. *Int. J. Electr. Power Energy Syst.* **2018**, *97*, 385–395. [[CrossRef](#)]
4. APS Panel and Public Affairs. *Integrating Renewable Electricity on the Grid A Report by the APS Panel on Public Affairs*; APS Panel and Public Affairs: Washington, DC, USA, 2010; pp. 1–38.
5. Alatrash, H.; Amarín, R.A.; Lam, C. Enabling large-scale PV integration into the grid. In Proceedings of the 2012 IEEE Green Technologies Conference, Tulsa, OK, USA, 19–20 April 2012. [[CrossRef](#)]
6. Anzalchi, A.; Sarwat, A. Overview of technical specifications for grid-connected photovoltaic systems. *Energy Convers. Manag.* **2017**, *152*, 312–327. [[CrossRef](#)]
7. Suma Jothibas, A.D.; Santoso, S. The Full Cost of Electricity (FCE) Integrating Photovoltaic Generation. *Integr. Photovolt. Gener.* **2016**. [[CrossRef](#)]
8. Ariyo, F.; Famutimi, B.; Olowu, T.; Akintade, S.; Abbas, A. Web-Based Application for the Sizing of a Photovoltaic (PV) Solar Power System. *American J. Eng. Res. (AJER)* **2016**, *5*, 219–222.
9. Mekonnen, Y.; Sarwat, A.I. Renewable energy supported microgrid in rural electrification of Sub-Saharan Africa. In Proceedings of the 2017 IEEE PES PowerAfrica, Accra, Ghana, 27–30 June 2017; pp. 595–599. [[CrossRef](#)]
10. International Renewable Energy Agency. *Data and Statistics—IRENA Resource*; International Renewable Energy Agency: Abu Dhabi, UAE, 2015.
11. Vandeliq, K.; Sophie, P.; Yves, P. *Assessment of the Environmental Performance of Solar Photovoltaic Technologies*; Environment Canada: Ottawa, ON, Canada, 2012; pp. 1–71.
12. The Statistics Portal. Solar PV—Statistics & Facts | Statista. The Statistics Portal. Available online: <https://www.statista.com/statistics/275932/world-construction-of-photovoltaic-systems-by-installed-capacity/> (accessed on 2 June 2018).
13. Lewis, N.S.; Nocera, D.G. Market Report Series: Renewables 2017. *J. Qual. Particip.* **2017**, *104*, 20142. [[CrossRef](#)]
14. Mohammadi, P.; Mehraeen, S. Challenges of PV Integration in Low-Voltage Secondary Networks. *IEEE Trans. Power Deliv.* **2017**, *32*, 525–535. [[CrossRef](#)]
15. Palmintier, B.; Broderick, R.; Mather, B.; Coddington, M.; Baker, K.; Ding, F.; Reno, M.; Lave, M.; Bharatkumar, A. *On the Path to SunShot: Emerging Issues and Challenges in Integrating Solar with the Distribution System*; Nrel/Tp-5D00-6533, Sand2016-2524 R; U.S. Department of Energy: Washington, DC, USA, 2016.
16. Appen, J.V.; Braun, M.; Stetz, T.; Diwold, K.; Geibel, D. Time in the Sun: The Challenge of High PV Penetration in the German Electric Grid. *IEEE Power Energy Mag.* **2013**, *11*, 55–64. [[CrossRef](#)]
17. Wu, Y.K.; Guan-Ting, Y.; Shaaban, M. Impact analysis of large PV integration: Case studies in Taiwan. In Proceedings of the 2016 IEEE/IAS 52nd Industrial and Commercial Power Systems Technical Conference (ICPS), Detroit, MI, USA, 1–5 May 2016; pp. 1–10. [[CrossRef](#)]
18. Rodriguez-Calvo, A.; Cossent, R.; Frías, P. Integration of PV and EVs in unbalanced residential LV networks and implications for the smart grid and advanced metering infrastructure deployment. *Int. J. Electr. Power Energy Syst.* **2017**, *91*, 121–134. [[CrossRef](#)]
19. Patsalides, M.; Stavrou, A.; Efthymiou, V.; Georghiou, G.E. Towards the establishment of maximum PV generation limits due to power quality constraints. *Int. J. Electr. Power Energy Syst.* **2012**, *42*, 285–298. [[CrossRef](#)]
20. Hoke, A.; Butler, R.; Hambrick, J.; Kroposki, B. Steady-State Analysis of Maximum Photovoltaic Penetration Levels on Typical Distribution Feeders. *IEEE Trans. Sustain. Energy* **2012**, *4*, 350–357. [[CrossRef](#)]
21. Mukwekwe, L.; Venugopal, C.; Davidson, I.E. A Review of The Impacts and Mitigation Strategies of High PV Penetration in Low Voltage Networks. In Proceedings of the 2017 IEEE PES PowerAfrica, Accra, Ghana, 27–30 June 2017; pp. 274–279. [[CrossRef](#)]
22. Cheng, D.; Mather, B.A.; Member, S.; Seguin, R.; Hambrick, J.; Broadwater, R.P.; Member, L. Photovoltaic (PV) Impact Assessment for Very High Penetration Levels. *IEEE J. Photovolt.* **2015**, *6*, 295–300. [[CrossRef](#)]

23. Yang, G.; Marra, F.; Juamperez, M.; Kjaer, S.B.; Hashemi, S.; Østergaard, J.; Ipsen, H.H.; Fredriksen, K.H. Voltage rise mitigation for solar PV integration at LV grids: Studies from PVNET. *dk. J. Mod. Power Syst. Clean Energy* **2015**, *3*, 411–421. [[CrossRef](#)]
24. Coddington, M.; Kroposki, B.; Basso, T.; Lynn, K.; Herig, C.; Bower, W. *High-Penetration Photovoltaic Standards and Codes Workshop*; NREL/Tp-550-48378; National Renewable Energy Laboratory (NREL): Golden, CO, USA, 2010; pp. 1–120.
25. Enslin, J.H.R. Network Impacts of High Penetration of Photovoltaic Solar Power Systems. In Proceedings of the IEEE PES General Meeting, Providence, RI, USA, 25–29 July 2010; pp. 1–5. [[CrossRef](#)]
26. Bank, J.; Mather, B.; Keller, J.; Coddington, M. High Penetration Photovoltaic Case Study Report High Penetration Photovoltaic Case Study Report. *Contract* **2013**, *303*, 275–3000.
27. Bebic, J. *Power System Planning: Emerging Practices Suitable for Evaluating the Impact of High-Penetration Photovoltaics*; Technical Report; National Renewable Energy Laboratory (NREL): Golden, CO, USA, 2008.
28. McPhail, D.; Croker, B.; Harvey, B. A study of solar PV saturation limits for representative low voltage networks. In Proceedings of the 2016 Australasian Universities Power Engineering Conference (AUPEC), Brisbane, QLD, Australia, 25–28 September 2016. [[CrossRef](#)]
29. Anzalchi, A.; Sundararajan, A.; Moghadasi, A.; Sarwat, A. Power quality and voltage profile analyses of high penetration grid-tied photovoltaics: A case study. In Proceedings of the 2017 IEEE Industry Applications Society Annual Meeting, Cincinnati, OH, USA, 1–5 October 2017; pp. 1–8. [[CrossRef](#)]
30. Weiss, J. Solar Energy Support in Germany. A Closer Look. In *Solar Energy Industries Association*; A report; The Brattle Group, Inc.: Cambridge, MA, USA, 2014.
31. Hancock, M.; MacGill, I.F. *Carnarvon: A Case Study of Increasing Levels of PV Penetration in an Isolated Electricity Supply System, a report by the UNSW Centre for Energy and Environmental Markets for the Australian PV Association*; Australian Solar Institute: Melbourne, Australia, 2012; pp. 1–49.
32. Denholm, P.; Margolis, R. *Energy Storage Requirements for Achieving 50% Solar Photovoltaic Energy Penetration in California*; NREL: Golden, CO, USA, 2016.
33. Ghosh, S.; Rahman, S. Global deployment of solar photovoltaics: Its opportunities and challenges. In Proceedings of the 2016 IEEE PES Innovative Smart Grid Technologies Conference Europe (ISGT-Europe), Ljubljana, Slovenia, 9–12 October 2016; pp. 1–6. [[CrossRef](#)]
34. US Department of Energy. *High Penetration of Photovoltaic (PV) Systems into the Distribution Grid*; Technical Report February; US Department of Energy: Washington, DC, USA, 2009.
35. Steen, D. Integrating Solar and Wind Into the Electricity Grid. In *Systems Perspectives on Renewable Power*; Chalmers University of Technology: Goteborg, Sweden, 2014; pp. 94–107, ISBN 978-91-980974-0-5.
36. Baquedano-Aguilar, M.D.; Colomé, D.G.; Agüero, E.; Molina, M.G. Impact of increased penetration of large-scale PV generation on short-term stability of power systems. In Proceedings of the 2016 IEEE 36th Central American and Panama Convention (CONCAPAN XXXVI), San Jose, Costa Rica, 9–11 November 2016; pp. 1–6. [[CrossRef](#)]
37. Stewart, E.; MacPherson, J.; Vasilic, S.; Nakafuji, D.; Aukai, T. *Analysis of High-Penetration Levels of Photovoltaics into the Distribution Grid on Oahu, Hawaii: Detailed Analysis of HECO Feeder WF1*; Technical Report; National Renewable Energy Laboratory (NREL): Golden, CO, USA, 2013.
38. European Photovoltaic Industry Association. *Connecting the Sun—Solar Photovoltaics on the Road To Large Scale Grid Integration*; European Photovoltaic Industry Association: Brussels, Belgium, 2012; pp. 1–120.
39. Phuangpornpitak, N.; Tia, S. Opportunities and Challenges of Integrating Renewable Energy in Smart Grid System. *Energy Procedia* **2013**, *34*, 282–290. [[CrossRef](#)]
40. Ding, M.; Xu, Z.; Wang, W.; Wang, X.; Song, Y.; Chen, D. A review on China’s large-scale PV integration: Progress, challenges and recommendations. *Renew. Sustain. Energy Rev.* **2016**, *53*, 639–652. [[CrossRef](#)]
41. Shah, R.; Mithulananthan, N.; Bansal, R.C.; Ramchandaramurthy, V.K. A review of key power system stability challenges for large-scale PV integration. *Renew. Sustain. Energy Rev.* **2015**, *41*, 1423–1436. [[CrossRef](#)]
42. Hou, J.; Xu, Y.; Liu, J.; Xin, L.; Wei, W. A multi-objective volt-var control strategy for distribution networks with high PV penetration. In Proceedings of the 10th International Conference on Advances in Power System Control, Operation Management (APSCOM 2015), Hong Kong, China, 8–12 November 2015; pp. 1–6. [[CrossRef](#)]

43. Mortazavi, H.; Mehrjerdi, H.; Saad, M.; Lefebvre, S.; Asber, D.; Lenoir, L. A Monitoring Technique for Reversed Power Flow Detection with High PV Penetration Level. *IEEE Trans. Smart Grid* **2015**, *6*, 2221–2232. [[CrossRef](#)]
44. Lewis, S. Analysis and management of the impacts of a high penetration of photovoltaic systems in an electricity distribution network. In Proceedings of the 2011 IEEE PES Innovative Smart Grid Technologies, Perth, WA, Australia, 13–16 November 2011; pp. 1–7.
45. Hossain, J. and Mahmud, A *Renewable Energy Integration Challenges and Solutions*; Springer Science & Business Media: Berlin, Germany, 2014; ISBN 978-981-4585-27-9.
46. Pooari, O.; Charoenlarnnoppaart, C. Harmonics Impact of Rooftop Photovoltaic Penetration Level on Low Voltage Distribution System. *Int. J. Electron. Electr. Eng.* **2016**, *4*, 221–225. [[CrossRef](#)]
47. Ketut, D.; Ricardo Austria, L.H.; Suehiro, M. Harmonic Issues That Limit Solar Photovoltaic. In *World Renewable Energy Forum (WREF); Colorado Convention Centre: Denver, CO, USA, 2012*; pp. 1–7.
48. Kadir, A.F.A.; Khatib, T.; Elmenreich, W. Integrating Photovoltaic Systems in Power System: Power Quality Impacts and Optimal Planning Challenges. *Int. J. Photoenergy* **2014**, *2014*. [[CrossRef](#)]
49. Tang, Y.; Ayyanar, R. Methodology of Automated Protection Analysis for Large Distribution Feeders with High Penetration of Photovoltaic Systems. *IEEE Power Energy Technol. Syst. J.* **2017**, *4*, 1–9. [[CrossRef](#)]
50. Ziadi, Z.; Taira, S.; Oshiro, M.; Funabashi, T. Optimal power scheduling for smart grids considering controllable loads and high penetration of photovoltaic generation. *IEEE Trans. Smart Grid* **2014**, *5*, 2350–2359. [[CrossRef](#)]
51. Taggart, D.; Hao, K.; Jenkins, R.; VanHatten, R. Power factor control for grid-tied photovoltaic solar farms. In Proceedings of the 14th Annual Western Power Delivery Automation Conference, Spokane, WA, USA, 27–29 March 2012.
52. Alet, P.J.; Bletterie, B.; Goršek, A.; Abart, A.; Heidl, M.; Baccaro, F.; Felice, M.D.; Efthymiou, V.; Mayr, C.; Graditi, G.; et al. Quantification, challenges and outlook of pv integration in the power system: A review by the european pv technology platform. In Proceedings of the 31st European Photovoltaic Solar Energy Conference and Exhibition- EU PVSEC 2015, Hamburg, Germany, 14–18 September 2015; pp. 2937–2943.
53. Katiraei, B.F. Studies for Utility-Scale Photovoltaic Distributed Generation. *IEEE Power Energy Mag.* **2011**, *9*, 62–71. [[CrossRef](#)]
54. Tan, Y.T. Impact on The Power System With a Large Penetration of Photovoltaic Generation. Ph.D. Thesis, University of Manchester Institute of Science and Technology, Manchester, UK, February 2004
55. Ebad, M.; Grady, W.M. An approach for assessing high-penetration PV impact on distribution feeders. *Electr. Power Syst. Res.* **2016**, *133*, 347–354. [[CrossRef](#)]
56. Xu, G.; Yu, W.; Griffith, D.; Golmie, N.; Moulema, P. Toward Integrating Distributed Energy Resources and Storage Devices in Smart Grid. *IEEE Internet Things J.* **2017**, *4*, 192–204. [[CrossRef](#)] [[PubMed](#)]
57. Tonkoski, R.; Turcotte, D.; El-Fouly, T.H. Impact of high PV penetration on voltage profiles in residential neighborhoods. *IEEE Trans. Sustain. Energy* **2012**, *3*, 518–527. [[CrossRef](#)]
58. Ibraheem, W.E.; Gan, C.K.; Ghani, M.R.A. Impact of Photovoltaic (PV) Systems on Distribution Networks. *Int. Rev. Model. Simul.* **2014**, *2*, 70–74.
59. Azmi, A.N.; Dahlberg, I.N.; Kolhe, M.L.; Imenes, A.G. Impact of increasing penetration of photovoltaic PV systems on distribution feeders. In Proceedings of the 2015 International Conference on Smart Grid and Clean Energy Technologies (ICSGCE), Offenburg, Germany, 20–23 October 2015; pp. 70–74.
60. Alam, M.J.E.; Muttaqi, K.M.; Sutanto, D.; Elder, L.; Baitch, A. *Performance Analysis of Distribution Networks under High Penetration of Solar PV Endeavour Energy Power Quality and Reliability Centre School of Electrical; Computer and Telecommunications Engineering University of Wollongong Australia: Wollongong, Australia, 2012*.
61. Cohen, M.A.; Callaway, D.S. Physical Effects of Distributed PV Generation on California’s Distribution System. *arXiv* **2015**, arXiv:1506.06643.
62. Hao, K.; Achanta, S.; Rowland, B.; Kivi, A. Mitigating the impacts of photovoltaics on the power system. In Proceedings of the 2016 Saudi Arabia Smart Grid (SASG), Jeddah, Saudi Arabia, 6–8 December 2016. [[CrossRef](#)]
63. Cohen, M.A.; Kauzmann, P.A.; Callaway, D.S. Economic Effects of Distributed PV Generation on California’s Distribution System. *J. Energy Inst.* **2015**, *128*, 126–138.

64. Anzalchi, A.; Pour, M.M.; Sarwat, A. A combinatorial approach for addressing intermittency and providing inertial response in a grid-connected photovoltaic system. In Proceedings of the 2016 IEEE Power and Energy Society General Meeting (PESGM), Boston, MA, USA, 17–21 July 2016; pp. 1–5. [[CrossRef](#)]
65. Sarwat, A.I.; Sundararajan, A.; Parvez, I.; Moghaddami, M.; Moghadasi, A. Toward a Smart City of Interdependent Critical Infrastructure Networks. In *Sustainable Interdependent Networks*; Springer: Berlin, Germany, 2018; pp. 21–45.
66. Sarwat, A.I.; Sundararajan, A.; Parvez, I. Trends and Future Directions of Research for Smart Grid IoT Sensor Networks. In *International Symposium on Sensor Networks, Systems and Security*; Springer: Berlin, Germany, 2017; pp. 45–61.
67. US Energy Information Administration. *Top 10 Net Solar Photovoltaic Generation from Utility and Small Scale, Year-to-Date through June 2017 (Thousand Megawatthours)*; US Energy Information Administration: Washington, DC, USA, 2017.
68. Feldman, D.; Boff, D.; Margolis, D.R. *Q3/Q4 2016 Solar Industry Update*; United States Department of Energy: Washington, DC, USA, 2016.
69. Wells, P. *Wind and Solar Data and Projections from the U.S. Energy Information Administration: Past Performance and Ongoing Enhancements*; U.S. Energy Information Administration (EIA): Washington, DC, USA, 2016.
70. Alam, M.J.; Muttaqi, K.M.; Sutanto, D. A novel approach for ramp-rate control of solar PV using energy storage to mitigate output fluctuations caused by cloud passing. *IEEE Trans. Energy Convers.* **2014**, *29*, 507–518. [[CrossRef](#)]
71. Kankiewicz, A.; Moon, D.; Sengupta, M. Observed Impacts of Transient Clouds on Utility-Scale PV Fields. *ASES Natl. Sol. Conf.* **2010**, *2009*, 1–4.
72. Francfort, J.; Briones, A.; Heitmann, P.; Schey, M.; Schey, S.; Smart, J. *Power Flow Regulations and Building Codes Review by the AVTA*; US Department of Energy: Washington, DC, USA, 2012.
73. Jeddi, N.; El Amraoui, L.; Rico, F.T. A comparative study and analysis of different models for photovoltaic (PV) array using in solar car. In Proceedings of the 2017 Twelfth International Conference on Ecological Vehicles and Renewable Energies (EVER), Monte Carlo, Monaco, 11–13 April 2017; pp. 1–10. [[CrossRef](#)]
74. Reinhardt, R.; Pautzke, F.; Schröter, M.; Wiemers, M. *Strategy: Comparative LCA of Wheel Hub Engine for Solar Car Application*; International Conference on Research and Education in Mechatronics (REM): Wolfenbuttel, Germany, 2017; pp. 1–6.
75. Amini, M.; Sarwat, A.I. Optimal reliability-based placement of plug-in electric vehicles in smart distribution network. *Int. J. Energy Sci.* **2014**, *4*, 2. [[CrossRef](#)]
76. Gholami, A.; Jamei, M.; Ansari, J.; Sarwat, A.I. Combined economic and emission dispatch incorporating renewable energy sources and plug-in hybrid electric vehicles. *Int. J. Energy Sci.* **2014**. [[CrossRef](#)]
77. Cao, C.; Wang, L.; Chen, B. Mitigation of the impact of high plug-in electric vehicle penetration on residential distribution grid using smart charging strategies. *Energies* **2016**, *9*, 1024. [[CrossRef](#)]
78. Alghsoon, E.; Harb, A.; Hamdan, M. Power Quality and Stability Impacts. In Proceedings of the 8th International Renewable Energy Congress (IREC), Amman, Jordan, 21 March–23 March 2017.
79. Wu, C.; Wen, F.; Lou, Y.; Xin, F. Probabilistic load flow analysis of photovoltaic generation system with plug-in electric vehicles. *Int. J. Electr. Power Energy Syst.* **2015**, *64*, 1221–1228. [[CrossRef](#)]
80. Memisevic, B.; Masic, F.; Bosovic, A.; Music, M. Impact of Plug-in Electric Vehicles and Photovoltaic Technologies on the Power Distribution Network (case-study of a suburban medium-voltage network). *Elektrotehnicki Vestnik* **2017**, *84*, 117–124.
81. Oviedo, R.M.; Fan, Z.; Gormus, S.; Kulkarni, P. A residential PHEV load coordination mechanism with renewable sources in smart grids. *Int. J. Electr. Power Energy Syst.* **2014**, *55*, 511–521. [[CrossRef](#)]
82. Gharaibeh, A.; Salahuddin, M.A.; Hussini, S.J.; Khreishah, A.; Khalil, I.; Guizani, M.; Al-Fuqaha, A. Smart Cities: A Survey on Data Management, Security and Enabling Technologies. *IEEE Commun. Surv. Tutor.* **2017**, *19*, 2456–2501. [[CrossRef](#)]
83. Akcin, M.; Kaygusuz, A.; Karabiber, A.; Alagoz, S.; Alagoz, B.B.; Keles, C. Opportunities for energy efficiency in smart cities. In Proceedings of the 4th International Istanbul Smart Grid Congress and Fair (ICSG), Istanbul, Turkey, 20–21 April 2016. [[CrossRef](#)]
84. Larsen, H. *Risø Energy Report 10: Energy for smart cities in an urbanised world*; Danmarks Tekniske Universitet, Risø National laboratoriet for Bæredygtig Energi: Forskningscenter Risoe, Denmark, 2011; ISBN 978-87-550-3905-6.

85. Coughlin, J.; Grove, J.; Irvine, L.; Jacobs, J.F.; Phillips, S.J.; Moynihan, L.; Wiedman, J. *A Guide to Community Solar: Utility, Private, and Non-Profit Development*; United States Department of Energy: Washington, DC, USA, 2010; p. 56.
86. Ghiani, E.; Garau, M.; Celli, G.; Pilo, F.; Marongiu, G. Smart integration and aggregation of nanogrids: Benefits for users and DSO. In Proceedings of the 2017 IEEE Manchester PowerTech, Manchester, UK, 18–22 June 2017; pp. 1–6. [[CrossRef](#)]
87. ENTSO-E. *Solar Eclipse March 2015: The Successful Stress Test of Europe's Power Grid—More Ahead*; Policy Brief; European Network of Transmission System Operators for Electricity: Brussels, Belgium, 2015.
88. Burges, K.; Döring, M.; Kuwahata, R.; Bachmann, U.; Sikora, R. Operating Power Systems with High Photovoltaic Generation during a Solar Eclipse Challenges and Operational Measures. In Proceedings of the 4th Solar Integration Workshop, Berlin, Germany, 10 November 2014.
89. Fritz, R. *How an Energy Supply System with a High PV Share Handled a Solar Eclipse*; International Energy Agency Photovoltaic Power Systems Programme: Kassel, Germany, 2016; pp. 1–18.
90. Maslo, K. Impact of Photovoltaics on Frequency Stability of Power System during Solar Eclipse. *IEEE Trans. Power Syst.* **2016**, *31*, 3648–3655. [[CrossRef](#)]
91. Amber, M. *Performance of ISO's System during 21 August 2017 Eclipse, California Independent System Operator Report*; California Independent System Operator: Folsom, CA, USA, 2017; pp. 1–32.
92. North American Electric Reliability. *A Wide-Area Perspective on the August 21*; 2017 Total Solar Eclipse White Paper; NERC: Atlanta, GA, USA, 2017.
93. U.S. Energy Information Administration. *Solar Eclipse on August 21 Will Affect Photovoltaic Generators Across the Country—Today in Energy—US*; U.S. Energy Information Administration: Washington, DC, USA, 2017.
94. Wikipedia. *Solar Eclipse of April 8, 2024*; Wikipedia: Washington, DC, USA, 2017.
95. NASA. *NASA—Solar Eclipses: 2021–2030*; NASA: Washington, DC, USA, 2013.
96. GWAC. GridWise Transactive Energy Framework Draft Version. *GridWise Archit. Counc. Trans. Energy* **2013**, *1*, 1–23.
97. Liu, Z.; Wu, Q.; Huang, S.; Zhao, H. Transactive energy: A review of state of the art and implementation. In Proceedings of the 2017 IEEE Manchester PowerTech, Manchester, UK, 18–22 June 2017; pp. 1–6. [[CrossRef](#)]
98. Sahin, T.; Shereck, D. Renewable Energy Sources in a Transactive Energy Market. In Proceedings of the 2014 2nd International Conference on Systems and Informatics (ICSAI 2014), Shanghai, China, 15–17 November 2014; pp. 202–208. [[CrossRef](#)]
99. Kristov, L.; Martini, P.D.; Taft, J.D. Two Visions of a Transactive Electric System. *IEEE Power and Energy Magazine*, May–June 2016, pp. 63–69.
100. The Grid Wise Architecture Council. *Harnessing Flexibility in an Evolving Electric Power System*. In *The Transactive Energy Conference and Workshop Proceedings*; The Grid Wise Architecture Council: Portland, OR, USA, 2016.
101. Terzi, D.S.; Arslan, B.; Sagioglu, S. Smart Grid Security Evaluation with a Big Data Use Case. In Proceedings of the 2018 IEEE 12th International Conference on Compatibility, Power Electronics and Power Engineering (CPE-POWERENG 2018), Doha, Qatar, 10–12 April 2018.
102. Nandury, S.V.; Begum, B.A. Big data for smart grid operation in smart cities. In Proceedings of the 2017 International Conference on Wireless Communications, Signal Processing and Networking (WiSPNET), Chennai, India, 22–24 March 2017; pp. 1507–1511. [[CrossRef](#)]
103. Bagheri, A.; Bollen, M.H.J.; Gu, I.Y.H. Big Data from Smart Grids. In Proceedings of the International Renewable and Sustainable Energy Conference (IRSEC), Beijing, China, 14–17 November 2016.
104. Wang, K.; Yu, J.; Yu, Y.; Qian, Y.; Zeng, D.; Guo, S.; Xiang, Y.; Wu, J. A Survey on Energy Internet: Architecture, Approach, and Emerging Technologies. *IEEE Syst. J.* **2017**, 1–14. [[CrossRef](#)]
105. Chin, W.L.; Li, W.; Chen, H.H. Energy Big Data Security Threats in IoT-Based Smart Grid Communications. *IEEE Commun. Mag.* **2017**, *55*, 70–75. [[CrossRef](#)]
106. Parvez, I.; Sundararajan, A.; Sarwat, A.I. Frequency band for HAN and NAN communication in Smart Grid. In Proceedings of the 2014 IEEE Symposium on Computational Intelligence Applications in Smart Grid (CIASG), Orlando, FL, USA, 9–12 December 2014; pp. 1–5. [[CrossRef](#)]
107. Yan, Y.; Qian, Y.; Sharif, H.; Tipper, D. A survey on smart grid communication infrastructures: Motivations, requirements and challenges. *IEEE Commun. Surv. Tutor.* **2013**, *15*, 5–20. [[CrossRef](#)]

108. Parvez, I.; Jamei, M.; Sundararajan, A.; Sarwat, A.I. RSS based loop-free compass routing protocol for data communication in advanced metering infrastructure (AMI) of Smart Grid. In Proceedings of the 2014 IEEE Symposium on Computational Intelligence Applications in Smart Grid (CIASG), Orlando, FL, USA, 9–12 December 2014; pp. 1–6. [[CrossRef](#)]
109. Ma, R.; Chen, H.H.; Huang, Y.R.; Meng, W. Smart grid communication: Its challenges and opportunities. *IEEE Trans. Smart Grid* **2013**, *4*, 36–46. [[CrossRef](#)]
110. Fan, Z.; Kulkarni, P.; Gormus, S.; Efthymiou, C.; Kalogridis, G.; Sooriyabandara, M.; Zhu, Z.; Lambbotharan, S.; Chin, W.H. Smart grid communications: Overview of research challenges, solutions, and standardization activities. *IEEE Commun. Surv. Tutor.* **2013**, *15*, 21–38. [[CrossRef](#)]
111. Ozgur, U.; Nair, H.T.; Sundararajan, A.; Akkaya, K.; Sarwat, A.I. An efficient MQTT framework for control and protection of networked cyber-physical systems. In Proceedings of the 2017 IEEE Conference on Communications and Network Security (CNS), Las Vegas, NV, USA, 9–11 October 2017; pp. 421–426.
112. Sundararajan, A.; Khan, T.; Aburub, H.; Sarwat, A.; Rahman, S. A Tri-Modular Human-on-the-Loop Framework for Intelligent Smart Grid Cyber-Attack Visualization. In Proceedings of the 2018 IEEE Southeast Conference, St. Petersburg, FL, USA, 19–22 April 2018.
113. Miranda, A.W.; Goldsmith, S. Cyber-physical risk management for PV photovoltaic plants. In Proceedings of the 2017 International Carnahan Conference on Security Technology (ICCST), Madrid, Spain, 23–26 October 2017; pp. 1–8. [[CrossRef](#)]
114. Liu, X.; Shahidehpour, M.; Cao, Y.; Wu, L.; Wei, W.; Liu, X. Microgrid Risk Analysis Considering the Impact of Cyber Attacks on Solar PV and ESS Control Systems. *IEEE Trans. Smart Grid* **2017**, *8*, 1330–1339. [[CrossRef](#)]
115. Zhong, X.; Jayawardene, I.; Venayagamoorthy, G.K.; Brooks, R. Denial of Service Attack on Tie-Line Bias Control in a Power System With PV Plant. *IEEE Trans. Emerg. Top. Comput. Intell.* **2017**, *1*, 375–390. [[CrossRef](#)]
116. Isozaki, Y.; Yoshizawa, S.; Fujimoto, Y.; Ishii, H.; Ono, I.; Onoda, T.; Hayashi, Y. On detection of cyber attacks against voltage control in distribution power grids. *IEEE Trans. Smart Grid* **2014**, *7*, 842–847. [[CrossRef](#)]
117. Chlela, M.; Mascarella, D.; Joos, G.; Kassouf, M. Cyber-resilient control of inverter based microgrids. Signal and Information Processing (GlobalSIP). In Proceedings of the 2016 IEEE Global Conference on Signal and Information Processing (GlobalSIP), Washington, DC, USA, 7–9 December 2016; pp. 841–845.
118. World Energy Council (WEC). *World Energy Resources: Solar 2016*; World Energy Council: London, UK, 2016; p. 6.
119. Fylladitakis, E. *Environmental Impacts of Photovoltaic Systems*; Brunel University: London, UK, 2016.
120. Ong, S.; Campbell, C.; Denholm, P.; Margolis, R.; Heath, G. *Land-Use Requirements for Solar Power Plants in the United States*; NREL: Golden, CO, USA, 2013.
121. Huang, B.; Zhao, J.; Chai, J.; Xue, B.; Zhao, F.; Wang, X. Environmental influence assessment of China's multi-crystalline silicon (multi-Si) photovoltaic modules considering recycling process. *Sol. Energy* **2017**, *143*, 132–141. [[CrossRef](#)]
122. Fthenakis, V.; Kim, H.C. Life-cycle uses of water in U.S. electricity generation. *Renew. Sustain. Energy Rev.* **2010**, *14*, 2039–2048. [[CrossRef](#)]
123. Tsoutsos, T.; Frantzeskaki, N.; Gekas, V. Environmental impacts from the solar energy technologies. *Energy Policy* **2005**, *33*, 289–296. [[CrossRef](#)]
124. Laleman, R.; Albrecht, J.; Dewulf, J. Life Cycle Analysis to estimate the environmental impact of residential photovoltaic systems in regions with a low solar irradiation. *Renew. Sustain. Energy Rev.* **2011**, *15*, 267–281. [[CrossRef](#)]
125. Mahajan, B. Negative environment impact of Solar Energy. *ReswarchGate* **2012**, *33*, 5.
126. Stadler, I. *Renewable Power Feeding to Distribution Networks Protected by Network Protection Relay—Problem Description and Possible Solutions*; Deutsche Gesellschaft für Internationale Zusammenarbeit (GIZ) GmbH: Bonn/Eschborn, Germany, 2014.
127. Coddington, M.; Kroposki, B.; Basso, T.; Lynn, K.; Sammon, D.; Yohn, T. *Photovoltaic Systems Interconnected onto Secondary Network Distribution Systems—Success Stories* *Photovoltaic Systems Interconnected onto Secondary Network Distribution Systems—Success Stories*; National Renewable Energy Laboratory: Golden, CO, USA, 2009.
128. Coddington, M. *Session 9: Photovoltaic System Case Studies and Electric Distribution Planning for DER*; National Renewable Energy Laboratory: Golden, CO, USA, 2015.

129. *Meting Notes from Interconnection of Minnesota Distributed Generation-Technical Meeting*; Division of Energy Resources, Minnesota Department of Commerce: Saint Paul, MN, USA, 2012; pp. 1–12.
130. Aman, M.M.; Bin Jasmon, G.; Bin Mokhlis, H.; Khan, Q.A.; Bakar, A.H.B.A.; Karimi, M. Modeling and simulation of digital frequency relay for generator protection. In Proceedings of the 2012 IEEE International Conference on Power and Energy (PECon), Kota Kinabalu, Malaysia, 2–5 December 2012; pp. 701–706. [[CrossRef](#)]
131. Bründlinger, R. *Advanced Smart Inverter and DER Functions Requirements in Latest European Grid Codes and Future Trends*; Solar Canada 2015 Conference, Metro Toronto Convention Centre: Toronto, ON, Canada, 2015; pp. 1–42.
132. Jordan, N. Integration of Network Protector Relays on Downtown Distribution Networks with Penetration of Renewable Energy. Master's Thesis, Louisiana State University, Baton Rouge, LA, USA, 2014.
133. Mack, R.; Sakib, M.; Succar, S. Impacts of substation transformer backfeed at high PV penetrations. In Proceedings of the 2017 IEEE Power Energy Society General Meeting, Chicago, IL, USA, 16–20 July 2017; pp. 1–5. [[CrossRef](#)]
134. IEEE Standards Coordinating Committee 21. *IEEE Standard for Interconnection and Interoperability of Distributed Energy Resources with Associated Electric Power Systems Interfaces*; IEEE Std 1547-2018 (Revision of IEEE Std 1547-2003); IEEE Standards Coordinating Committee 21: Piscataway, NJ, USA, 2018; pp. 1–138. [[CrossRef](#)]
135. Moghadasi, A.; Sargolzaei, A.; Khalilnejad, A.; Moghaddami, M.; Sarwat, A. Model predictive power control approach for three-phase single-stage grid-tied PV module-integrated converter. In Proceedings of the 2016 IEEE Industry Applications Society Annual Meeting, Portland, OR, USA, 2–6 October 2016; pp. 1–6. [[CrossRef](#)]
136. Patil, S.D.; Kadwane, S.G.; Gawande, S.P. Current Control of Grid Tied Inverter through SHEPWM Method. *Energy Procedia* **2017**, *117*, 643–650. [[CrossRef](#)]
137. Li, H.; Wen, C.; Chao, K.H.; Li, L.L. Research on Inverter Integrated Reactive Power Control Strategy in the Grid-Connected PV Systems. *Energies* **2017**, *10*, 912. [[CrossRef](#)]
138. Jafarian, H.; Kim, N.; Parkhideh, B.; Enslin, J. Analysis of smart inverter functions of decentralized grid-connected AC-stacked PV inverter architecture. In Proceedings of the IEEE Applied Power Electronics Conference and Exposition—APEC, Tampa, FL, USA, 26–30 March 2017; pp. 3594–3600. [[CrossRef](#)]
139. Todeschini, G. Control and derating of a PV inverter for harmonic compensation in a smart distribution system. In Proceedings of the 2017 IEEE Power Energy Society General Meeting, Chicago, IL, USA, 16–20 July 2017; pp. 1–5. [[CrossRef](#)]
140. MDPI. *Advanced Energy Storage Technologies and Their Applications (AESAs)*; MDPI: Basel, Switzerland, 2018. [[CrossRef](#)]
141. Zhou, H.; Bhattacharya, T.; Tran, D.; Siew, T.S.T.; Khambadkone, A.M. Composite energy storage system involving battery and ultracapacitor with dynamic energy management in microgrid applications. *IEEE Trans. Power Electr.* **2011**, *26*, 923–930. [[CrossRef](#)]
142. Blonbou, R.; Monjoly, S.; Bernard, J.L. Dynamic Energy Storage Management for Dependable Renewable Electricity Generation. In *Energy Storage*; Zobia, A.F., Ed.; InTech: Rijeka, Croatia, 2013; Chapter 11. [[CrossRef](#)]
143. Pinto, S.F.; Mendes, P.V.; Fernando Silva, J. Modular Matrix Converter Based Solid State Transformer for smart grids. *Electr. Power Syst. Res.* **2016**, *136*, 189–200. [[CrossRef](#)]
144. Al-Hafri, A.; Ali, H.; Ghias, A.; Nasir, Q. Transformer-less based solid state transformer for intelligent power management. In Proceedings of the 5th International Conference on Electronic Devices, Systems and Applications (ICEDSA), Ras Al Khaimah, UAE, 6–8 December 2016; pp. 1–4. [[CrossRef](#)]
145. Vaca-Urbano, F.; Alvarez-Alvarado, M.S. Power quality with solid state transformer integrated smart-grids. In Proceedings of the 2017 IEEE PES Innovative Smart Grid Technologies Conference—Latin America, ISGT Latin America 2017, Quito, Ecuador, 20–22 September 2017; pp. 1–6. [[CrossRef](#)]
146. Sam, D. Are Solid-State Transformers Ready for Prime Time? *Power Electr.* Available online: <http://www.powerelectronics.com/alternative-energy/are-solid-state-transformers-ready-prime-time> (accessed on 26 June 2017).
147. Yu, W. *Solid State Transformer for Power Distribution Applications*; US Department of Energy: Washington, DC, USA, 2017.

148. Van Der Merwe, J.W.; Du, H. The solid-state transformer concept: A new era in power distribution. In Proceedings of the IEEE AFRICON Conference, Nairobi, Kenya, 23–25 September 2009. [\[CrossRef\]](#)
149. Abdella, J.; Shuaib, K. Peer to Peer Distributed Energy Trading in Smart Grids: A Survey. *Energies* **2018**, *11*, 1560. [\[CrossRef\]](#)
150. Hong, J.S.; Kim, M. Game-Theory-Based Approach for Energy Routing in a Smart Grid Network. *J. Comput. Netw. Commun.* **2016**, *2016*. [\[CrossRef\]](#)
151. Nguyen, P.H.; Kling, W.L.; Georgiadis, G.; Papatriantafidou, M.; Tuan, L.A.; Bertling, L. Distributed routing algorithms to manage power flow in agent-based active distribution network. In Proceedings of the IEEE PES Innovative Smart Grid Technologies Conference Europe, ISGT Europe, Gothenberg, Sweden, 11–13 October 2010; pp. 1–7. [\[CrossRef\]](#)
152. Kado, Y.; Shichijo, D.; Wada, K.; Iwatsuki, K. Multiport power router and its impact on future smart grids. *Radio Sci.* **2016**, *51*, 1234–1246. [\[CrossRef\]](#)
153. Hayashi, K.; Kato, R.; Torii, R.; Taoka, H.; Abe, R. Bi-directional power flow through a digital grid router. *J. Int. Counc. Electr. Eng.* **2015**, *5*, 42–46. [\[CrossRef\]](#)
154. Liu, Y.; Fang, Y.; Li, J. Interconnecting microgrids via the energy router with smart energy management. *Energies* **2017**, *10*, 1297. [\[CrossRef\]](#)
155. Kordonis, A.; Takahashi, R.; Hikihara, T. AC/AC converter towards power routing systems in smart-grids: Advantage on operation by nonlinear dynamics. In Proceedings of the 2013 IEEE 2nd Global Conference on Consumer Electronics, GCCE 2013, Tokyo, Japan, 1–4 October 2013; pp. 158–159. [\[CrossRef\]](#)
156. Xu, Y.; Zhang, J.; Wang, W.; Juneja, A.; Bhattacharya, S. Energy router: Architectures and functionalities toward energy internet. In Proceedings of the 2011 IEEE International Conference on Smart Grid Communications, SmartGridComm 2011, Brussels, Belgium, 17–20 October 2011; pp. 31–36. [\[CrossRef\]](#)
157. Zhu, Q.; Wei, D.; Basar, T. Secure routing in smart grids. In Proceedings of the Workshop on Foundations of Dependable and Secure Cyber-Physical Systems (FDSCPS), CPSWeek 2011, Chicago, IL, USA, 11–14 April 2011; pp. 55–59.
158. Wang, J.; OU, Q.; Shen, H. An overview of smart grid routing algorithms. *AIP Conf. Proc.* **2017**, *1864*, 020098.
159. Lin, J.; Yu, W.; Yang, X.; Xu, G.; Zhao, W. On false data injection attacks against distributed energy routing in smart grid. In Proceedings of the 2012 IEEE/ACM 3rd International Conference on Cyber-Physical Systems, ICCPS 2012, Beijing, China, 17–19 April 2012; pp. 183–192. [\[CrossRef\]](#)
160. Lee, R. *Software Engineering, Artificial Intelligence, Networking and Parallel/Distributed Computing*; Springer: Berlin, Germany, 2009; Volume 209. [\[CrossRef\]](#)
161. Baggu, M.; Kevin, S. Advanced Distribution Management Systems and Distribution Automation. In Proceedings of the Distribution Systems and Planning Training for New England Conference of Public Utility Commissioners GRID, 27–29 September 2017.
162. Lightner, E. *Advanced Distribution Management Systems*; US Department of Energy: Washington, DC, USA, 2015.
163. Mcnair, D.E.; Phelan, D.J.; Coleman, L. *Voices of Experience: Insights into Advanced Distribution Management Systems*; US Department of Energy: Washington, DC, USA, 2015.
164. Goel, N.; Agarwal, M. Smart grid networks: A state of the art review. In Proceedings of the 2015 International Conference on Signal Processing and Communication (ICSC), Noida, India, 16–18 March 2015; pp. 122–126. [\[CrossRef\]](#)
165. Schneider Electric. *Creating a Reliable and Secure Advanced Distribution Management System*; White Paper; Schneider Electric: Rueil-Malmaison, France, 2014.
166. Schneider Electric DMS NS. *Advanced Distribution Management System (ADMS)*; Schneider Electric: Rueil-Malmaison, France, 2017; pp. 1–20.
167. Aljahani, M.E. An Enhanced Self-Healing Protection System in Smart Grid: Using Advanced and Intelligent Devices and Applying Hierarchical Routing in Sensor Network Technique. Master's Thesis, Western Michigan University, Kalamazoo, Michigan, June 2014; p. 50.
168. Voima, S.; Laaksonen, H.; Kauhaniemi, K. Adaptive protection scheme for smart grids. In Proceedings of the 12th IET International Conference on Developments in Power System Protection (DPSP 2014), Copenhagen, Denmark, 31 March–3 April 2014; pp. 1–6. [\[CrossRef\]](#)
169. Kauhaniemi, K.; Voima, S. Adaptive Relay Protection Concept for Smart Grids. In Proceedings of the Renewable Efficient Energy II Conference, Vaasa, Finland, 21–22 March 2012; pp. 21–22.

170. Papaspiliotopoulos, V.A.; Korres, G.N.; Hatziaargyriou, N.D. Protection coordination in modern distribution grids integrating optimization techniques with adaptive relay setting. In Proceedings of the 2015 IEEE Eindhoven PowerTech, PowerTech 2015, Eindhoven, The Netherlands, 29 June–2 July 2015. [[CrossRef](#)]
171. Bertolo, M. Adaptive Protection Algorithms for Smart Distribution Systems Tested in a Hardware-in-the-Loop Setup. Master's Thesis, POLITECNICO DI MILANO, School of Industrial and Information Engineering, Milan, Italy, 27 July 2017; pp. 1–90.
172. Ates, Y.; Boynuegri, A.; Uzunoglu, M.; Nadar, A.; Yumurtaci, R.; Erdinc, O.; Paterakis, N.; Catalão, J. Adaptive Protection Scheme for a Distribution System Considering Grid-Connected and Islanded Modes of Operation. *Energies* **2016**, *9*, 378. [[CrossRef](#)]
173. Hussain, A.; Kim, H.M. A hybrid framework for adaptive protection of microgrids based on IEC 61850. *Int. J. Smart Home* **2016**, *10*, 285–296. [[CrossRef](#)]
174. Manditereza, P.T.; Bansal, R.C. Multi-Agent Based Distributed Voltage Control Algorithm for Smart Grid Applications. *Electr. Power Compon. Syst.* **2016**, *44*, 2352–2363. [[CrossRef](#)]
175. Merabet, G.H.; Essaaidi, M.; Talei, H.; Abid, M.R.; Khalil, N.; Madkour, M.; Benhaddou, D. Applications of Multi-Agent Systems in Smart Grids: A survey. In Proceedings of the 2014 International Conference on Multimedia Computing and Systems (ICMCS), Marrakech, Morocco, 14–16 April 2014; pp. 1088–1094. [[CrossRef](#)]
176. Xie, J.; Liu, C.C. Multi-agent systems and their applications. *J. Int. Counc. Electr. Eng.* **2017**, *7*, 188–197. [[CrossRef](#)]
177. Yilmaz, C.; Albayrak, S.; Marco, L. Smart Grid Architectures and the Multi-Agent System Paradigm. In Proceedings of the The Fourth International Conference on Smart Grids, Green Communications and IT Energy-aware Technologies, Chamonix, France, 20–24 April 2014; pp. 90–95.
178. Sampaio, R.F.; Melo, L.S.; Leão, R.P.; Barroso, G.C.; Bezerra, J.R. Automatic restoration system for power distribution networks based on multi-agent systems. *IET Gener. Transm. Distrib.* **2017**, *11*, 475–484. [[CrossRef](#)]
179. Wan, H.; Li, K.K.; Wong, K.P. An adaptive multiagent approach to protection relay coordination with distributed generators in industrial power distribution system. *IEEE Trans. Ind. Appl.* **2010**, *46*, 2118–2124. [[CrossRef](#)]
180. Peidaee, P.; Kalam, A.; Moghaddam, M.H. Developing a Simulation Framework for Integrating Multi-Agent Protection System into Smart Grids. In Proceedings of the 2017 Australasian Universities Power Engineering Conference (AUPEC), Melbourne, Australia, 19–22 November 2017.
181. Liu, C.; Hussain, Z.; Chen, Z.; Leth, C. Multi-agent system based adaptive protection for dispersed generation integrated distribution systems. *Int. J. Smart Grid Clean Energy* **2013**, *2*, 406–412. [[CrossRef](#)]
182. Nick, M.; Cherkaoui, R.; Paolone, M. Optimal siting and sizing of distributed energy storage systems via alternating direction method of multipliers. In Proceedings of the 2014 Power Systems Computation Conference, Wroclaw, Poland, 18–22 August 2014; pp. 1–7. [[CrossRef](#)]
183. Sok, V.; Tayjasanant, T. Determination of optimal siting and sizing of energy storage system in PV-connected distribution systems considering minimum energy losses. In Proceedings of the ECTI-CON 2017—2017 14th International Conference on Electrical Engineering/Electronics, Computer, Telecommunications and Information Technology, Phuket, Thailand, 27–30 June 2017; pp. 451–454. [[CrossRef](#)]
184. Reddy, S.Y.; Reddy, D.S.; Rao, G.K. Optimal siting and sizing of solar power sources in interconnection grid system. *J. Electr. Eng.* **2016**, *16*, 1–8. [[CrossRef](#)]
185. Jamaly, M.; Bosch, J.L.; Kleissl, J. Aggregate ramp rates of distributed photovoltaic systems in San Diego county. *IEEE Trans. Sustain. Energy* **2013**, *4*, 519–526. [[CrossRef](#)]
186. Gong, Q.; Lei, J.; Ye, J. Optimal Siting and Sizing of Distributed Generators in Distribution Systems Considering Cost of Operation Risk. *Energies* **2016**, *9*, 61. [[CrossRef](#)]
187. Mukerji, M. Optimal Siting and Sizing of Solar Photovoltaic Distributed Generation to Minimize Loss, Present Value of Future Asset Upgrades and Peak Demand Costs on a Real Distribution Feeder. Master's Thesis, University of Waterloo, Waterloo, ON, Canada, 2011; pp. 1–97.
188. Luo, L.; Gu, W.; Zhang, X.P.; Cao, G.; Wang, W.; Zhu, G.; You, D.; Wu, Z. Optimal siting and sizing of distributed generation in distribution systems with PV solar farm utilized as STATCOM (PV-STATCOM). *Appl. Energy* **2018**, *210*, 1092–1100. [[CrossRef](#)]

189. Sukumar, S.; Mokhlis, H.; Mekhilef, S.; Karimi, M.; Raza, S. Ramp-rate control approach based on dynamic smoothing parameter to mitigate solar PV output fluctuations. *Int. J. Electr. Power Energy Syst.* **2018**, *96*, 296–305. [[CrossRef](#)]
190. Jewell, W.; Ramakumar, R. The effects of moving clouds on electric utilities with dispersed photovoltaic generation. *IEEE Trans. Energy Convers.* **1987**, *EC-2*, 570–576. [[CrossRef](#)]
191. Jewell, W.T.; Unruh, T.D. Limits on cloud-induced fluctuation in photovoltaic generation. *IEEE Trans. Energy Convers.* **1990**, *5*, 8–14. [[CrossRef](#)]
192. Kern, E.; Russell, M. Spatial and temporal irradiance variations over large array fields. In Proceedings of the Conference Record of the Twentieth IEEE Photovoltaic Specialists Conference, Las Vegas, NV, USA, 26–30 September 1988; pp. 1043–1050. [[CrossRef](#)]
193. Wiemken, E.; Beyer, H.; Heydenreich, W.; Kiefer, K. Power characteristics of PV ensembles: Experiences from the combined power production of 100 grid connected PV systems distributed over the area of Germany. *Sol. Energy* **2001**, *70*, 513–518. [[CrossRef](#)]
194. Curtright, A.E.; Apt, J. The character of power output from utility-scale photovoltaic systems. *Prog. Photovolt. Res. Appl.* **2008**, *16*, 241–247. [[CrossRef](#)]
195. Liu, C.; Chau, K.; Zhang, X. An efficient wind–photovoltaic hybrid generation system using doubly excited permanent-magnet brushless machine. *IEEE Trans. Ind. Electr.* **2010**, *57*, 831–839.
196. Al-Masri, H.M.; Ehsani, M. Feasibility Investigation of a Hybrid On-Grid Wind Photovoltaic Retrofitting System. *IEEE Trans. Ind. Appl.* **2016**, *52*, 1979–1988. [[CrossRef](#)]
197. Cao, Y.; Zhang, Y.; Zhang, H.; Shi, X.; Terzija, V. Probabilistic Optimal PV Capacity Planning for Wind Farm Expansion Based on NASA Data. *IEEE Trans. Sustain. Energy* **2017**, *8*, 1291–1300. [[CrossRef](#)]
198. Mangu, B.; Akshatha, S.; Suryanarayana, D.; Fernandes, B.G. Grid-Connected PV-Wind-Battery-Based Multi-Input Transformer-Coupled Bidirectional DC-DC Converter for Household Applications. *IEEE J. Emerg. Sel. Top. Power Electr.* **2016**, *4*, 1086–1095. [[CrossRef](#)]
199. Huber, M.; Weissbart, C. On the optimal mix of wind and solar generation in the future Chinese power system. *Energy* **2015**, *90*, 235–243. [[CrossRef](#)]
200. Akram, U.; Khalid, M.; Shafiq, S. Optimal sizing of a wind/solar/battery hybrid grid-connected microgrid system. *IET Renew. Power Gener.* **2018**, *12*, 72–80. [[CrossRef](#)]
201. Askarzadeh, A. Electrical power generation by an optimised autonomous PV/wind/tidal/battery system. *IET Renew. Power Gener.* **2017**, *11*, 152–164. [[CrossRef](#)]
202. Wang, H.; Huang, J. Joint Investment and Operation of Microgrid. *IEEE Trans. Smart Grid* **2017**, *8*, 833–845. [[CrossRef](#)]
203. Wang, H.; Huang, J. Cooperative Planning of Renewable Generations for Interconnected Microgrids. *IEEE Trans. Smart Grid* **2016**, *7*, 2486–2496. [[CrossRef](#)]
204. Su, C.L.; Kirschen, D. Quantifying the effect of demand response on electricity markets. *IEEE Trans. Power Syst.* **2009**, *24*, 1199–1207.
205. Mohsenian-Rad, A.H.; Leon-Garcia, A. Optimal residential load control with price prediction in real-time electricity pricing environments. *IEEE Trans. Smart Grid* **2010**, *1*, 120–133. [[CrossRef](#)]
206. Khodaei, A.; Shahidepour, M.; Bahramirad, S. SCUC with hourly demand response considering intertemporal load characteristics. *IEEE Trans. Smart Grid* **2011**, *2*, 564–571. [[CrossRef](#)]
207. Wang, Y.; Pordanjani, I.R.; Xu, W. An event-driven demand response scheme for power system security enhancement. *IEEE Trans. Smart Grid* **2011**, *2*, 23–29. [[CrossRef](#)]
208. Kandasamy, N.K.; Tseng, K.J.; Boon-Hee, S. Virtual storage capacity using demand response management to overcome intermittency of solar PV generation. *IET Renew. Power Gener.* **2017**, *11*, 1741–1748. [[CrossRef](#)]
209. Mortaji, H.; Ow, S.H.; Moghavvemi, M.; Almurib, H.A.F. Load Shedding and Smart-Direct Load Control Using Internet of Things in Smart Grid Demand Response Management. *IEEE Trans. Ind. Appl.* **2017**, *53*, 5155–5163. [[CrossRef](#)]
210. Karapetyan, A.; Khonji, M.; Chau, C.K.; Elbassioni, K.; Zeineldin, H.H. Efficient Algorithm for Scalable Event-based Demand Response Management in Microgrids. *IEEE Trans. Smart Grid* **2016**, *9*, 2714–2725. [[CrossRef](#)]
211. Sivaneasan, B.; Kandasamy, N.K.; Lim, M.L.; Goh, K.P. A new demand response algorithm for solar PV intermittency management. *Appl. Energy* **2018**, *218*, 36–45. [[CrossRef](#)]

212. Sundararajan, A.; Sarwat, A.I. Roadmap to prepare distribution grid-tied photovoltaic site data for performance monitoring. In Proceedings of the 2017 International Conference on Big Data, IoT and Data Science (BIGD), Pune, India, 20–22 December 2017; pp. 110–115. [[CrossRef](#)]
213. Karakaya, Z. Software engineering issues in big data application development. In Proceedings of the 2017 International Conference on Computer Science and Engineering (UBMK), Antalya, Turkey, 5–8 October 2017; pp. 851–855. [[CrossRef](#)]
214. El-Seoud, S.A.; El-Sofany, H.F.; Abdelfattah, M.A.F.; Mohamed, R. Big Data and Cloud Computing: Trends and Challenges. *Int. J. Interact. Mob. Technol.* **2017**, *11*, 34. [[CrossRef](#)]
215. Yang, C.; Huang, Q.; Li, Z.; Liu, K.; Hu, F. Big Data and cloud computing: Innovation opportunities and challenges. *Int. J. Digit. Earth* **2017**, *10*, 13–53. [[CrossRef](#)]
216. Yang, C.; Yao, J.; Lou, W.; Xie, S. On Demand Response Management Performance Optimization for Microgrids under Imperfect Communication Constraints. *IEEE Internet Things J.* **2017**, *4*, 881–893. [[CrossRef](#)]
217. Dubey, V.; Agrawal, P. Cloud Computing and Data Management. In Proceedings of the Symposium on Colossal Data Analysis and Networking (CDAN), Indore, India, 18–19 March 2016; pp. 1–6. [[CrossRef](#)]
218. Gontar, Z.H.; Patnaik, S. (Eds.) *Smart Grid Analytics for Sustainability and Urbanization*; Advances in Computer and Electrical Engineering; IGI Global: Hershey, PA, USA, 2018. [[CrossRef](#)]
219. Zhou, Y.; Zhang, D.; Xiong, N. Post-cloud computing paradigms: A survey and comparison. *Tsinghua Sci. Technol.* **2017**, *22*, 714–732. [[CrossRef](#)]
220. Mohamed, N.; Al-Jaroodi, J.; Jawhar, I.; Lazarova-Molnar, S.; Mahmoud, S. SmartCityWare: A Service-Oriented Middleware for Cloud and Fog Enabled Smart City Services. *IEEE Access* **2017**, *5*, 17576–17588. [[CrossRef](#)]
221. Alrawais, A.; Althothaily, A.; Hu, C.; Cheng, X. Fog Computing for the Internet of Things: Security and Privacy Issues. *IEEE Internet Comput.* **2017**, *21*, 34–42. [[CrossRef](#)]
222. Zheng, Z.; Song, L.; Han, Z.; Li, G.Y.; Poor, H.V. Game Theoretic Approaches to Massive Data Processing in Wireless Networks. *IEEE Wirel. Commun.* **2017**, *25*, 98–104.
223. Bruce, L.M. Game theory applied to big data analytics in geosciences and remote sensing. In Proceedings of the 2013 IEEE International Geoscience and Remote Sensing Symposium—IGARSS, Melbourne, VIC, Australia, 21–26 July 2013; pp. 4094–4097. [[CrossRef](#)]
224. Wei, L.; Sundararajan, A.; Sarwat, A.I.; Biswas, S.; Ibrahim, E. A distributed intelligent framework for electricity theft detection using benford’s law and stackelberg game. In Proceedings of the 2017 Resilience Week (RWS), Wilmington, DE, USA, 18–22 September 2017; pp. 5–11. [[CrossRef](#)]
225. Lu, X.; Shi, H.; Biswas, R.; Javed, M.H.; Panda, D.K. DLoBD: A Comprehensive Study of Deep Learning over Big Data Stacks on HPC Clusters. *IEEE Trans. Multi Scale Comput. Syst.* **2018**. [[CrossRef](#)]
226. Mohammadi, M.; Al-Fuqaha, A.; Sorour, S.; Guizani, M. Deep Learning for IoT Big Data and Streaming Analytics: A Survey. *IEEE Commun. Surv. Tutor.* **2018**. [[CrossRef](#)]
227. Yan, H.; Wan, J.; Zhang, C.; Tang, S.; Hua, Q.; Wang, Z. Industrial Big Data Analytics for Prediction of Remaining Useful Life Based on Deep Learning. *IEEE Access* **2018**, *6*, 17190–17197. [[CrossRef](#)]
228. Araki, T.; Nakamura, Y. Future trend of deep learning frameworks; From the perspective of big data analytics and HPC. In Proceedings of the 2017 Asia-Pacific Signal and Information Processing Association Annual Summit and Conference (APSIPA ASC), Kuala Lumpur, Malaysia, 12–15 December 2017; pp. 696–703. [[CrossRef](#)]
229. Xiao, C.; Wang, L.; Jie, Z.; Chen, T. A Multi-level Intelligent Selective Encryption Control Model for Multimedia Big Data Security in Sensing System with Resource Constraints. In Proceedings of the 2016 IEEE 3rd International Conference on Cyber Security and Cloud Computing (CSCloud), Beijing, China, 25–27 June 2016; pp. 148–153. [[CrossRef](#)]
230. Puthal, D.; Wu, X.; Nepal, S.; Ranjan, R.; Chen, J. SEEN: A Selective Encryption Method to Ensure Confidentiality for Big Sensing Data Streams. *IEEE Trans. Big Data* **2017**. [[CrossRef](#)]
231. Gai, K.; Qiu, M.; Zhao, H. Privacy-Preserving Data Encryption Strategy for Big Data in Mobile Cloud Computing. *IEEE Trans. Big Data* **2017**. [[CrossRef](#)]
232. Mavroeidakos, T.; Michalas, A.; Vergados, D.D. Security architecture based on defense in depth for Cloud Computing environment. In Proceedings of the 2016 IEEE Conference on Computer Communications Workshops (INFOCOM WKSHPS), San Francisco, CA, USA, 10–14 April 2016; pp. 334–339. [[CrossRef](#)]

233. Hurst, W.; Merabti, M.; Fergus, P. Big Data Analysis Techniques for Cyber-threat Detection in Critical Infrastructures. In Proceedings of the 2014 28th International Conference on Advanced Information Networking and Applications Workshops, Victoria, BC, Canada, 13–16 May 2014; pp. 916–921. [[CrossRef](#)]
234. Youssef, A.; El-Telbany, M.; Zekry, A. The role of artificial intelligence in photo-voltaic systems design and control: A review. *Renew. Sustain. Energy Rev.* **2017**, *78*, 72–79. [[CrossRef](#)]
235. Kumar, K.R.; Kalavathi, M.S. Artificial intelligence based forecast models for predicting solar power generation. *Mater. Today Proc.* **2018**, *5*, 796–802. [[CrossRef](#)]
236. Kermadi, M.; Berkouk, E.M. Artificial intelligence-based maximum power point tracking controllers for Photovoltaic systems: Comparative study. *Renew. Sustain. Energy Rev.* **2017**, *69*, 369–386. [[CrossRef](#)]
237. Lars, L.; Elizabeth, T. The benefits, risks, and future of artificial intelligence in solar and wind energy. In *Making Renewables Smarter*; Group Technology and Research Position Paper; DNV GL: Oslo, Norway, 2017.



© 2018 by the authors. Licensee MDPI, Basel, Switzerland. This article is an open access article distributed under the terms and conditions of the Creative Commons Attribution (CC BY) license (<http://creativecommons.org/licenses/by/4.0/>).